

# special communication

## A novel method to study contraction characteristics of a single cardiac myocyte using carbon fibers

SO-ICHIRO YASUDA,<sup>1</sup> SEIRYO SUGIURA,<sup>1</sup> NAOSHI KOBAYAKAWA,<sup>1</sup> HIDEO FUJITA,<sup>1</sup> HIROSHI YAMASHITA,<sup>1</sup> KAORU KATOH,<sup>2</sup> YASUTAKE SAEKI,<sup>3</sup> HIROKO KANEKO,<sup>4</sup> YOSHIHISA SUDA,<sup>5</sup> RYOZO NAGAI,<sup>1</sup> AND HARUO SUGI<sup>6</sup>

<sup>1</sup>Department of Cardiovascular Medicine, Graduate School of Medicine, University of Tokyo, Tokyo 113-8655; <sup>2</sup>Supermolecular Division, Electrotechnical Laboratory, Tsukuba 305-8568;

<sup>3</sup>Department of Physiology, Dental School, Tsurumi University, Yokohama 230-0063;

<sup>4</sup>Tsukuba Materials Information Laboratory Company, Tsukuba 305-0051; <sup>5</sup>Mitsubishi Pencil Company, Fujioka 375-8501; and <sup>6</sup>Department of Physiology, School of Medicine, Teikyo University, Tokyo 173-8605, Japan

Received 9 March 2001; accepted in final form 14 May 2001

**Yasuda, So-ichiro, Seiryō Sugiura, Naoshi Kobayakawa, Hideo Fujita, Hiroshi Yamashita, Kaoru Katoh, Yasutake Saeki, Hiroko Kaneko, Yoshihisa Suda, Ryozo Nagai, and Haruo Sugi.** A novel method to study contraction characteristics of a single cardiac myocyte using carbon fibers. *Am J Physiol Heart Circ Physiol* 281: H1442–H1446, 2001.—To facilitate cardiac muscle research, we developed a novel method by which the force and length of a single ventricular myocyte can be recorded with a pair of carbon graphite fibers attached firmly to both ends. One fiber was stiff, whereas the other fiber was compliant to allow the recording of force and shortening during twitch contractions. The image of the compliant carbon fiber was projected onto a pair of photodiodes, and their output was fed to a piezoelectric transducer after variable amplifications to alter the effective compliance of the carbon fiber. Thus contraction of the myocyte was induced under virtually isometric conditions as well as under auxotonic conditions. We obtained a bell-shaped relation between the compliance under an auxotonic load and the work output of the myocyte, which was directly related to myocyte performance in the heart. Because it is easy to attach myocytes to the experimental apparatus, the present method would allow us to study cardiac muscle mechanics at the cellular and molecular levels.

carbon graphite fiber; isometric contraction

IN THE FIELD of cardiac muscle research, the use of isolated single myocytes is essential not only to study cardiac muscle contraction characteristics without the complications arising from heterogeneity in electrical activation and contraction in multicellular prepara-

tions (3, 4), but also to investigate the effect of gene transfer on cardiac muscle performance at the cellular and the molecular level, providing basic information about the gene therapy of cardiac diseases (2, 10, 11). To conduct the mechanics experiments in which the length and force of the preparation should be recorded under a variety of conditions, both ends of the preparation should be firmly attached to the experimental apparatus. This is not easy with single myocytes because of their small size and the absence of tendons at both ends.

Several methods have been developed to attach myocytes, including the use of glass microneedles (5), suction micropipettes (4), and adhesives (12). Despite the development of these methods, however, the experiments with single myocytes require an enormous technical skill and appear not to be free from damage to the cell membrane and stray compliance at its attached ends. In addition to the above methods, Le Guennec et al. (9) used carbon fibers, to which myocytes firmly attached; the attachment is likely to be due to electrostatic forces between the carbon fiber surface and the myocyte surfaces (7). Although the use of carbon fibers greatly reduced the need for technical expertise, its compliance allowed full activation only at short sarcomere length.

In the experiments to be described in this paper, we succeeded in developing a novel method in which carbon graphite fiber compliance can be altered by a feedback system so that myocytes are made to contract

Address for reprint requests and other correspondence: S. Sugiura, Dept. of Cardiovascular Medicine, Graduate School of Medicine, Univ. of Tokyo, Hongo 7-3-1, Bunkyo-ku, Tokyo 113-8655, Japan (E-mail: sugiura-2im@h.u-tokyo.ac.jp).

The costs of publication of this article were defrayed in part by the payment of page charges. The article must therefore be hereby marked "advertisement" in accordance with 18 U.S.C. Section 1734 solely to indicate this fact.

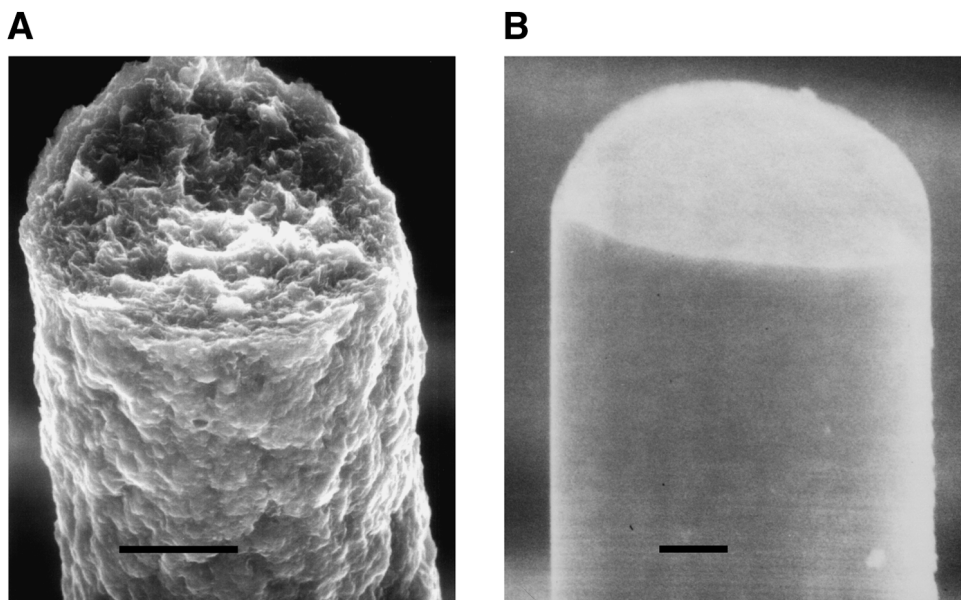

Fig. 1. A: scanning electron micrographs of carbon fiber used in the present study. Bar = 10  $\mu\text{m}$ . B: commercially available amorphous carbon fiber. Bar = 1  $\mu\text{m}$ .

not only isometrically, but also under various compliance of auxotonic loads, providing a powerful means for studying cardiac muscle function at the cellular and the molecular level.

## METHODS

**Myocyte preparation and experimental setup.** Hearts were removed from pentobarbital sodium-anesthetized (50 mg/kg) adult male Wistar rats (200–300 g), and the aorta was cannulated so that we could perfuse the heart with a series of solutions kept at 37°C; namely, 1.8 mM  $\text{Ca}^{2+}$  HEPES-Tyrode solution (in mM: 137 NaCl, 5.4 KCl, 1.8  $\text{CaCl}_2$ , 0.5  $\text{MgCl}_2$ , 0.33  $\text{NaH}_2\text{PO}_4$ , 5 HEPES, 5 glucose, pH 7.4 adjusted by NaOH at 22°C) for 5 min,  $\text{Ca}^{2+}$ -free HEPES-Tyrode solution for 4 min, and  $\text{Ca}^{2+}$ -free HEPES-Tyrode solution containing 0.2 mg/ml collagenase (Nitta Zerachin, Osaka, Japan) and 0.04 mg/ml protease (type XIV, Sigma) for 4 min. The left ventricle was then cut into small pieces and gently stirred in 0.2 mM  $\text{Ca}^{2+}$  HEPES-Tyrode solution for 10 min at 37°C. After the solution was sieved through a 220- $\mu\text{m}$  nylon mesh to remove undigested ventricular tissues, ventricular myocytes were collected by centrifugation of the cell suspension and were resuspended in 1.8 mM  $\text{Ca}^{2+}$  HEPES-Tyrode solution containing 1% bovine serum albumin (Fraction V, Sigma). The myocyte suspension thus obtained was introduced into an experimental chamber mounted on the stage of an inverted microscope (objective  $\times 40$ , numerical aperture 0.75, IMT-2, Olympus; Tokyo, Japan). A single rod-shaped myocyte was selected, and both of its ends were attached to a pair of carbon fibers, each connected to a micromanipulator. The myocyte held between the carbon fibers was stretched to a sarcomere length of 2.0–2.2  $\mu\text{m}$  and stimulated to contract with current pulses given through a pair of platinum plate electrodes. Temperature of the solution was kept at 37°C with a thermoelectric device (Thermoplate, TOKAI HIT).

**Carbon fiber.** A new type of carbon fiber that contains many fine graphite crystal granules was used for the present study. These fibers are called Graphite Reinforced by Carbon (GRC) fibers and were fabricated and patented by H. Kaneko

and Y. Suda.<sup>1</sup> A mixture of the fine graphite granules (1–5  $\mu\text{m}$  in diameter) and resin oligomer is kneaded well and is shaped into rods by thrusting through a thin hole in the sapphire. This thrusting process lines up the edges of the fine graphite granules, which are rich in charged residues, in the same direction and increases the amount of surface charges on the carbon fiber. The fibers are then carbonized at 1500°C and made into GRC fibers. The GRC fibers (Fig. 1A) are different from commercially available amorphous carbon fibers (Fig. 1B) in their shape and in their surface charges. The GRC fibers exhibited a bumpy surface in contrast with the smooth surface of amorphous carbon fibers. Bumps of GRC fibers correspond to the graphite granules that enrich fiber surface charges. The amount of fiber surface charges was measured by an electrochemical method (cyclic voltammetry).

We found that myocytes attached to the GRC fibers much more firmly than to the amorphous carbon fibers, and we decided to use the former in the present experiments. The firm attachment of myocytes to the GRC fibers may result from a large amount of surface charges of the fiber.

**Feedback system.** As illustrated in Fig. 2, a single myocyte preparation (M) was held horizontally between a pair of carbon fibers. One fiber ( $C_1$ ) was thick and rigid (diameter, 30–40  $\mu\text{m}$ ; compliance, 0.015–0.02 m/N) and served as the mechanical ground, whereas the other fiber ( $C_2$ ) was thin and compliant (diameter, 5–7  $\mu\text{m}$ ; compliance 5.5–7.5 m/N) and was used to record length changes of the preparation. The carbon fiber compliance was determined by pushing it against a glass needle of a known compliance (13). The myocyte image was obtained with a CCD camera (DC-77RR, Sony) and recorded with a videocassette recorder (VO-900, Sony) at 30 frames/s to be displayed on a monitor screen (15  $\times$  20 cm). The myocyte image was split with a half mirror, and the image of  $C_2$  fiber at the point of attachment of the myocyte was projected onto a pair of photodiodes ( $\text{PD}_1$  and

<sup>1</sup>Patent No: US 5218757, DE 4123534 C2, Fr 2664734, UK GB2246202, JP 2655742, and JP 2574495. These GRC fibers are available from Tsukuba Materials Information Laboratory, Ltd. (E-mail: BYC01367@nifty.ne.jp).

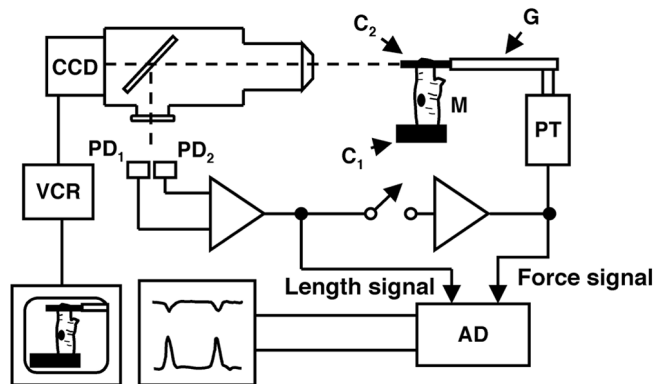

Fig. 2. Diagram of experimental arrangement. A myocyte (M) is held between a pair of carbon graphite fibers ( $C_1$  and  $C_2$ ) connected to glass rods (G). The image of  $C_2$  fiber at the point of attachment of the myocyte is projected onto a pair of photodiodes ( $PD_1$  and  $PD_2$ ). Differential output of the photodiodes (myocyte length signal) is applied to the feedback circuit driving the piezoelectric transducer (PT). AD: data acquisition system. For further explanation see text.

$PD_2$ ) (S4201, Hamamatsu Photonics), of which the differential output was a linear function of the  $C_2$  fiber deflection induced by shortening of the myocyte (8). The myocyte length signal was applied, after appropriate amplification, to the feedback circuit driving the piezoelectric transducer (PT) (PI polytechnique), which was connected to a glass rod supporting the  $C_2$  fiber in such a way that the PT pulled the glass rod laterally to reduce the deflection of the  $C_2$  fiber at its attachment to the myocyte. Thus, by changing the loop gain of the feedback system, we could change the effective compliance of the  $C_2$  fiber. If the gain was large enough, the  $C_2$  fiber compliance was made very close to zero (see Fig. 4) and the myocyte contracted virtually isometrically. By changing the loop gain, the myocyte contracted against various auxotonic loads, i.e., against a linear spring with variable compliance (see Fig. 6). The feedback signal fed to the PT served as the myocyte force signal. The length and force signals were digitized and stored at 1 kHz by a data acquisition system (AD) (Power Lab/400, AD Instruments) connected to and controlled by a personal computer and displayed on the monitor screen.

**Statistical analysis.** For the comparison of mean between the two groups, Student's *t*-test was used.

## RESULTS

**Firm attachment of myocyte to the carbon fiber.** When the carbon graphite fiber was gently brought into contact with the surface of a myocyte lying with its long axis at right angles with the carbon fiber, the myocyte attached firmly to the fiber. This attachment procedure was very easy and did not require any special technical skill. In Fig. 3, A and B, a single myocyte is held between  $C_1$  and  $C_2$  fibers at two different lengths. The average sarcomere length is  $1.9 \mu\text{m}$  in Fig. 3A and  $2.1 \mu\text{m}$  in Fig. 3B. As shown, the myocyte can be stretched uniformly along its entire length as judged from its uniform sarcomere spacing. In fact, Fourier transform of the longitudinal sarcomere spacings of the myocyte in A and B exhibited sarcomere length spectra with sharp peaks at  $1.9$  and  $2.1 \mu\text{m}$ , respectively (Fig. 3C).

When the myocyte was stretched beyond 1.3–1.5 times its slack length,  $C_2$  fiber bent considerably due to

the increasing force excited on it, and it finally detached from the myocyte. The force required to detach the fiber from the myocyte was  $2.42 \pm 0.39 \mu\text{N}$  (means  $\pm$  SD,  $n = 5$ ), much larger than the maximum isometric force generated by the myocyte even under positive inotropic interventions ( $-1.3 \mu\text{N}$ , described later).

**Recording of twitches under isometric and auxotonic conditions.** Figure 4 shows records of twitches of a single ventricular myocyte stimulated at 5-s intervals. In the first and the fourth twitches, the myocyte was allowed to shorten by simply bending a  $C_2$  carbon fiber with a relatively small compliance ( $5.5 \text{ m/N}$ ) while the feedback system was switched off. On the other hand,

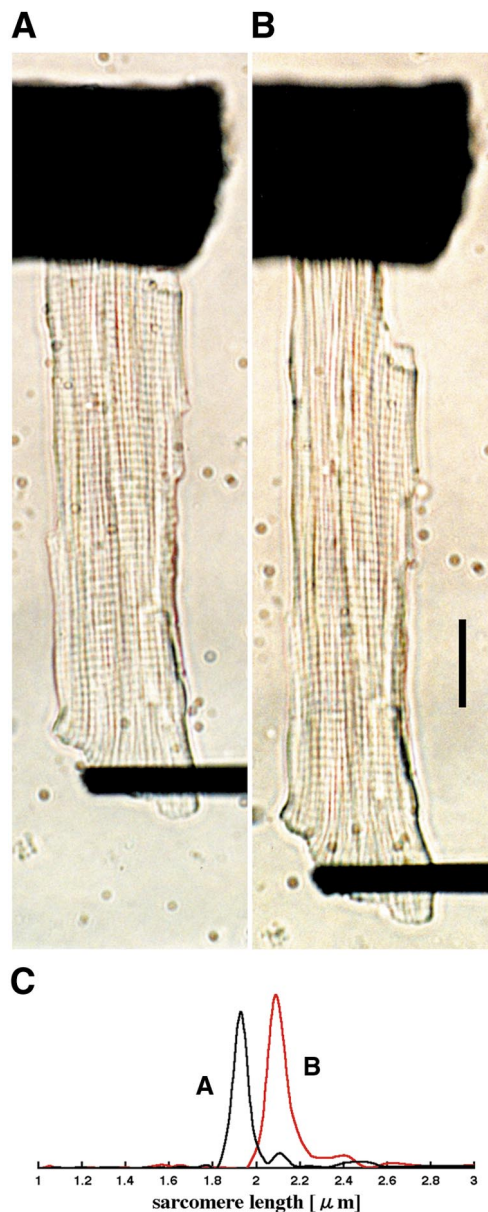

Fig. 3. A single myocyte held between a pair of carbon graphite fibers at two different lengths. Average sarcomere length was  $1.9 \mu\text{m}$  in A and  $2.1 \mu\text{m}$  in B. Bar =  $20 \mu\text{m}$ . Sarcomere length spectra corresponding to the myocyte in A and B are shown in C.

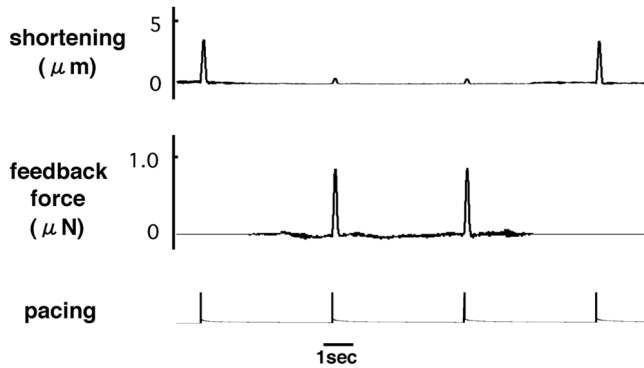

Fig. 4. Records of four consecutive twitches of a single ventricular myocyte showing the effect of feedback control (stimulation frequency 0.2 Hz). *Top*, *middle*, and *bottom* traces show shortening, force development of the myocyte, and pacing spike, respectively.

the second and the third twitches were recorded under virtually isometric conditions, which were achieved by the feedback system operating with its appropriate loop gain, so that the apparent compliance of the thin carbon fiber was reduced (length change  $<0.5\%$  of the slack length of the myocyte preparation). Close microscopic observation of the myocyte during the isometric twitch indicated the striation spaces along its entire length were kept virtually unchanged at any transverse optical section. This implied that, although the myocyte was attached to the carbon fibers on one side of its surface, the lateral connection of the component myofibrils was rigid enough to keep lateral alignment of the myofibrils unchanged.

In Fig. 5, isometric force tracings were compared under different contractile conditions. With inotropic intervention by adding  $10 \mu\text{M}$  of isoproterenol to the buffer, peak twitch force increased significantly [ $1.06 \pm 0.20 \mu\text{N}$  (force per cross-sectional area:  $2.91 \pm 0.65 \text{ mN/mm}^2$ ),  $n = 5$ ] from the control [ $0.73 \pm 0.17 \mu\text{N}$  (force per cross-sectional area:  $2.0 \pm 0.43 \text{ mN/mm}^2$ ),  $n = 5$ ] ( $P < 0.05$ ). This increase in peak force was accompanied by the increase in the rate of force generation and relaxation similar to that observed in other experimental preparations.

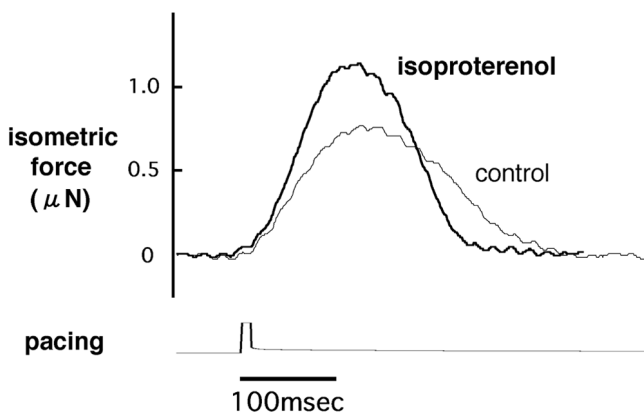

Fig. 5. Effect of inotropic intervention on isometric twitch force. Thin line, control; thick line,  $10 \mu\text{M}$  isoproterenol.

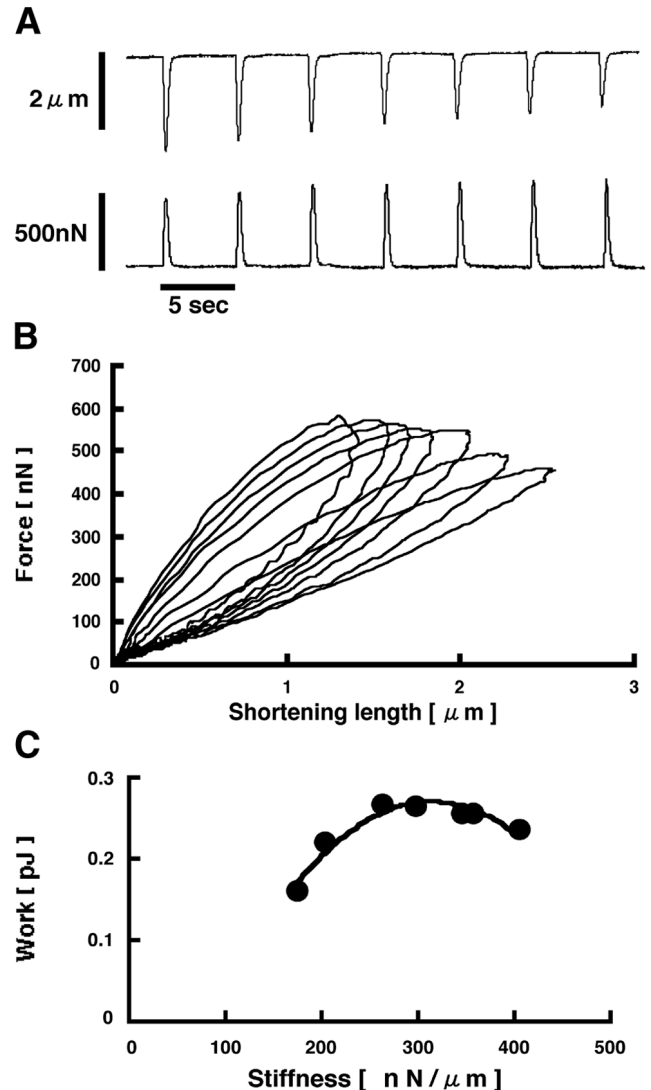

Fig. 6. Work output of a single ventricular myocyte during twitches under various compliances of auxotonic load. *A*: length (*top trace*) and force (*bottom trace*) changes of consecutive twitches under various compliances of auxotonic load. *B*: length-force loops of the twitches shown in *A*. *C*: relation between the work output in a twitch and the stiffness of auxotonic load.

Because the effective compliance of  $C_2$  fiber can be altered by changing the loop gain of the feedback system, we also recorded twitches of a myocyte under various compliances of auxotonic load. As shown in Fig. 6A, the myocyte was stimulated at 5-s intervals, and its changes in length and force during twitches were recorded under various compliances of auxotonic load. At the present stage, such a wide range of change in the effective compliance is achieved only with  $C_2$  fibers with a relatively large compliance ( $>7.0 \text{ mN}$ ), and it is not easy to produce the virtually isometric condition with such compliant  $C_2$  fibers. Efforts are being made to overcome this technical difficulty. Figure 6B shows the length-force loops of the twitches obtained from the records in Fig. 6A. Because the loop exhibited counter-clockwise rotation, the area surrounded by the loop represented the amount of work output by the myocyte

for a given auxotonic load. As can be seen in Fig. 6C, the work output during a twitch was maximum at an intermediate compliance of auxotonic load, whereas it approached zero when the compliance of auxotonic load tended to zero or increased beyond the intermediate value. The auxotonic load versus work output relation was similar in shape to the isotonic load versus work output relation in skeletal muscle fibers first described by Fenn (6).

## DISCUSSION

Using the carbon graphite fibers to which cardiac myocytes can firmly attach, we have succeeded in developing a novel method to study the characteristics of contraction of single ventricular myocytes, which has two distinct advantages over other methods hitherto developed. One advantage is the extreme easiness in firmly attaching a myocyte to the carbon fibers. As already described in METHODS, the firm myocyte attachment to the carbon graphite fiber seems to be associated with its bumpy surface structure (Fig. 1A), which increases the effective surface area carrying charges for the electrostatic binding between the myocyte and the carbon fiber. Despite the very firm attachment between the myocyte and the carbon fiber, enough to support the myocyte generating its maximum isometric force, we noticed no sign of myocyte damage around the area of attachment; the maximum isometric force of the myocyte recorded in the present study was reproducible and its magnitude was comparable with that reported previously by other authors (4). The uniform sarcomere spacing along the entire length of the preparation was also maintained for more than 30–40 min.

Another advantage of the present method is, therefore, that it enables us to record twitch contractions of a single myocyte not only under isometric conditions, but also under auxotonic conditions directly related to ventricular myocyte performance during systole of the heart (Figs. 4 and 6). In congestive heart failure, the heart is known to work against an abnormally high afterload (1). By changing the loop gain of the feedback system, the myocyte can be made to shorten against various auxotonic loads, and the relation between work output and afterload can be obtained to examine whether failing myocardium adapts to a high load or

not. This line of information will surely contribute to the understanding of the pathophysiology of heart failure. In addition to these advantages, our new method has a potential ability to record optical signals from the myocyte, such as  $\text{Ca}^{2+}$  transients, together with its mechanical responses. It is in our program to study the dependence of  $\text{Ca}^{2+}$  transients in the myocyte on the load to obtain information about how intracellular  $\text{Ca}^{2+}$  cycling is influenced by external mechanical conditions.

## REFERENCES

1. **Asanoi H, Sasayama S, and Kameyama T.** Ventriculoarterial coupling in normal and failing heart in humans. *Circ Res* 65: 483–493, 1989.
2. **Barry WH.** Molecular inotropy. A future approach to the treatment of heart failure? *Circulation* 100: 2303–2304, 1999.
3. **Bluhm WF, McCulloch AD, and Lew WY.** Active force in rabbit ventricular myocytes. *J Biomech* 28: 1119–1122, 1995.
4. **Brady AJ.** Mechanical properties of isolated cardiac myocytes. *Physiol Rev* 71: 413–428, 1991.
5. **Fabiato A.** Myoplasmic free calcium concentration reached during the twitch of an intact isolated cardiac cell and during calcium-induced release of calcium from the sarcoplasmic reticulum of a skinned cardiac cell from the adult rat or rabbit ventricle. *J Gen Physiol* 78: 457–497, 1981.
6. **Fenn WO.** The relation between the work performed and the energy liberated in muscular contraction. *J Physiol (Lond)* 58: 373–395, 1924.
7. **Garnier D.** Attachment procedures for mechanical manipulation of isolated cardiac myocytes: a challenge. *Cardiovasc Res* 28: 1958–1964, 1994.
8. **Kamimura S.** Direct measurement of nanometric displacement under an optical microscope. *Applied Optics* 26: 3425–3427, 1987.
9. **Le Guennec JY, Peineau N, Argibay JA, Mongo KG, and Garnier D.** A new method of attachment of isolated mammalian ventricular myocytes for tension recording: length dependence of passive and active tension. *J Mol Cell Cardiol* 22: 1083–1093, 1990.
10. **Michele DE, Albayya FP, and Metzger JM.** Direct, convergent hypersensitivity of calcium-activated force generation produced by hypertrophic cardiomyopathy mutant alpha-tropomyosins in adult cardiac myocytes. *Nat Med* 5: 1413–1417, 1999.
11. **Rust EM, Albayya FP, and Metzger JM.** Identification of a contractile deficit in adult cardiac myocytes expressing hypertrophic cardiomyopathy-associated mutant troponin T proteins. *J Clin Invest* 103: 1459–1467, 1999.
12. **Shepherd N and Kavalier F.** Direct control of contraction force of single frog atrial cells by extracellular ions. *Am J Physiol Cell Physiol* 251: C653–C661, 1986.
13. **Yoneda M.** Force exerted by a single cilium of *Mytilus Edulus*. *I. Exo Biol* 37: 461–468, 1960.