



VisWeek 08
VIS • INFOVIS • VAST

Edge Groups: An Approach to Understanding the Mesh Quality of Marching Methods

Carlos A. Dietrich, Carlos Scheidegger

João L. D. Comba, Luciana Porcher Nedel, Cláudio T. Silva

Triangle Quality of Marching Cubes

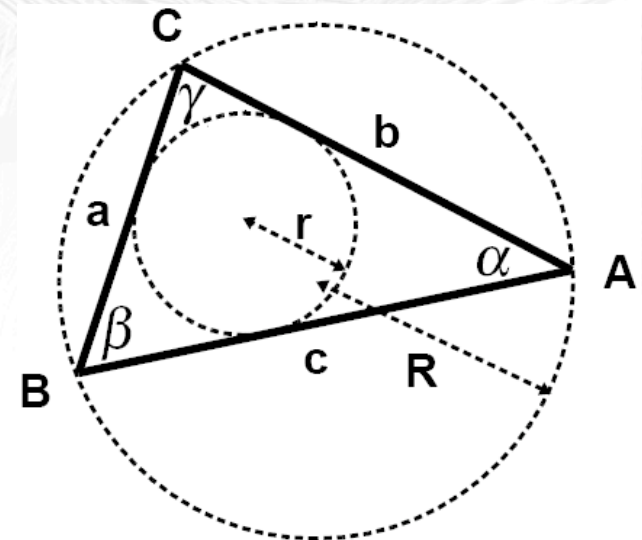
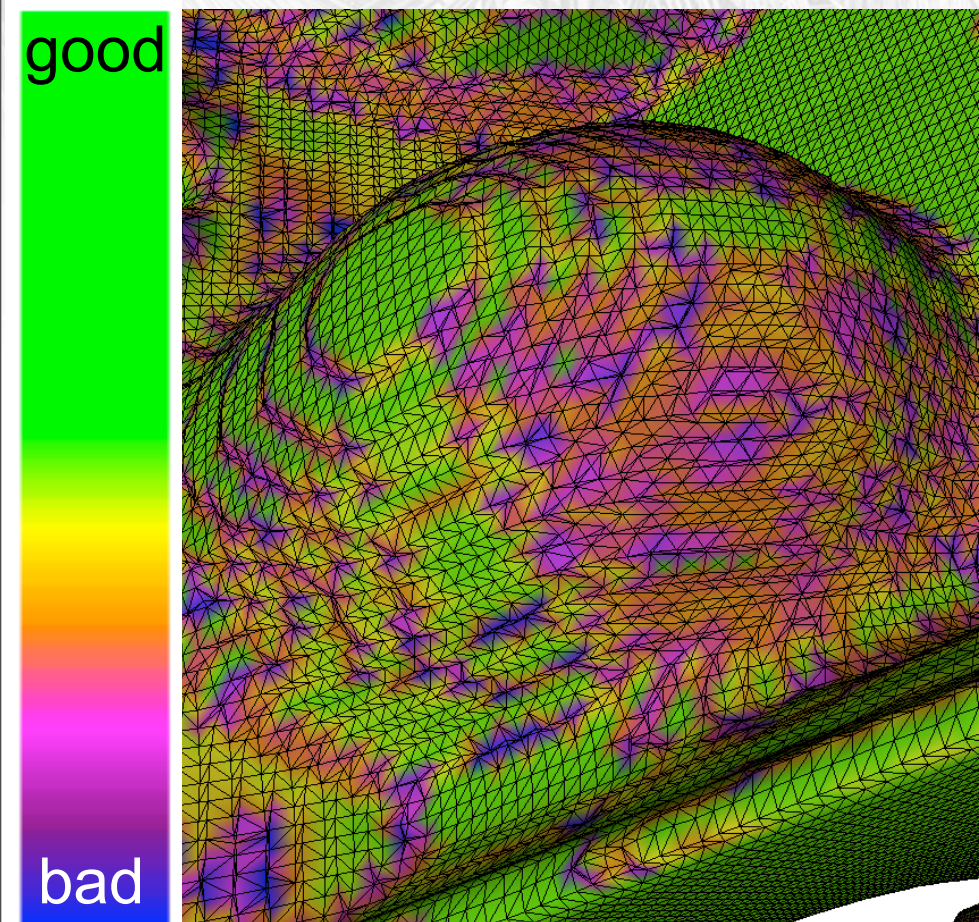

Radii ratio ($2r/R$)

Triangle Quality of Marching Cubes

- Mostly good quality triangles. But some very poor quality triangles

good

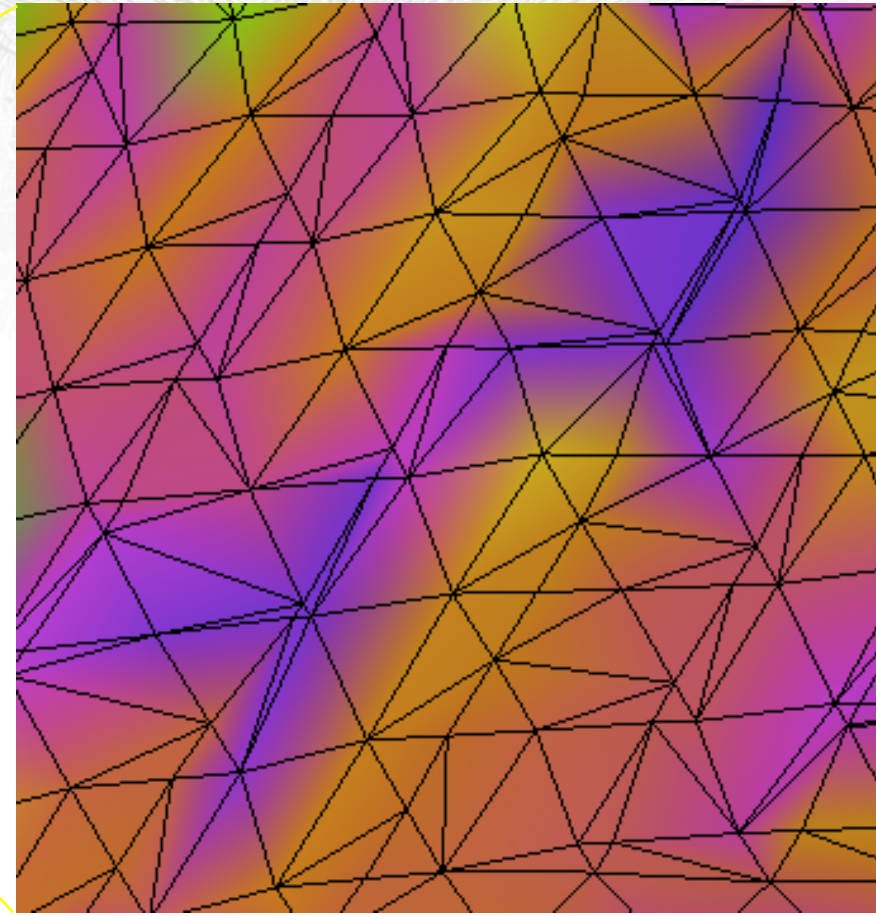
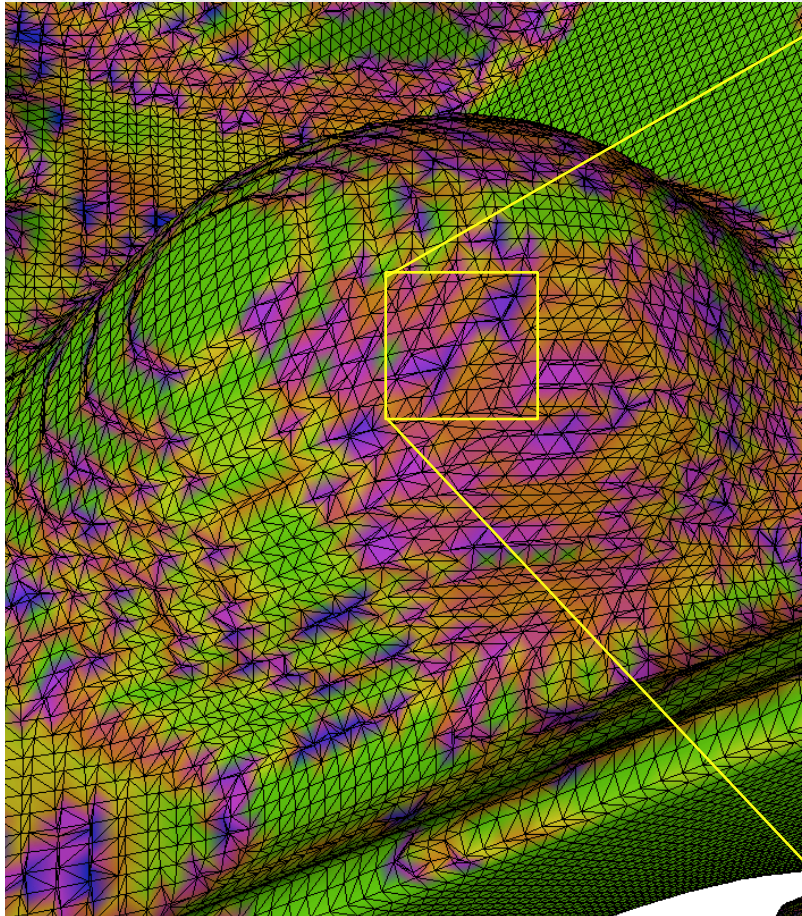

bad

Triangle Quality of Marching Cubes

- In this work we propose a way to understand why this happens.

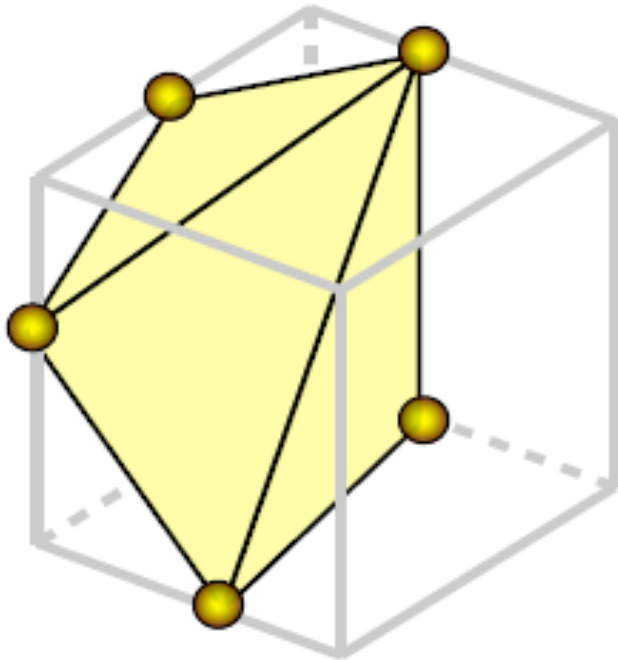

Triangle Quality of Marching Cubes

- Look at each triangle individually

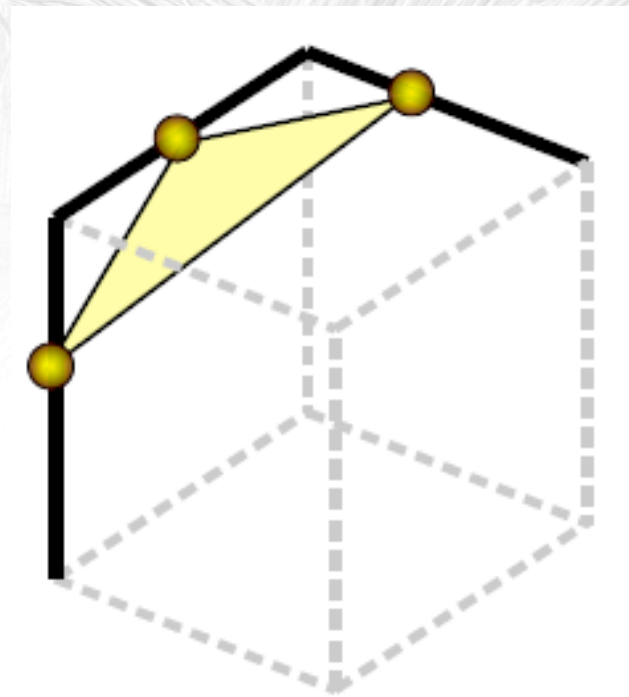
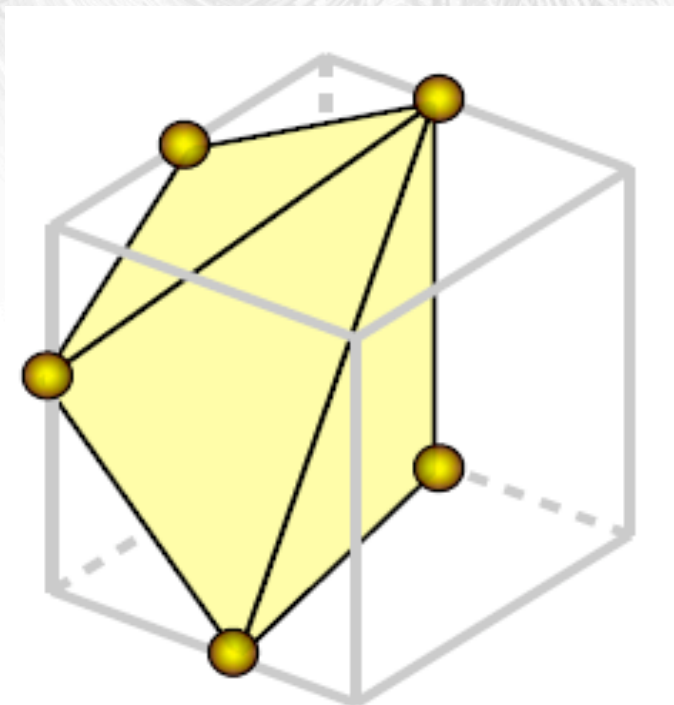

Important Observation:

Each triangle generated by MC has vertices only over active edges. Therefore, it **does not** generate arbitrary triangles

Triangle Quality of Marching Cubes

- Look at each triangle individually

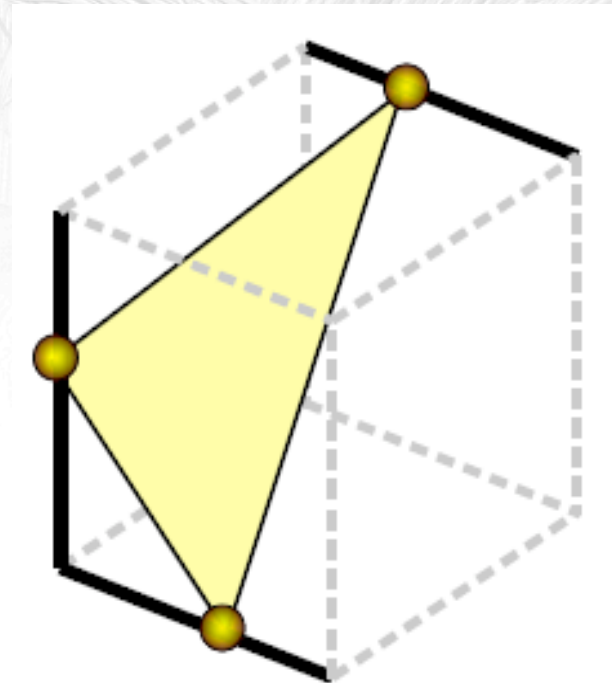
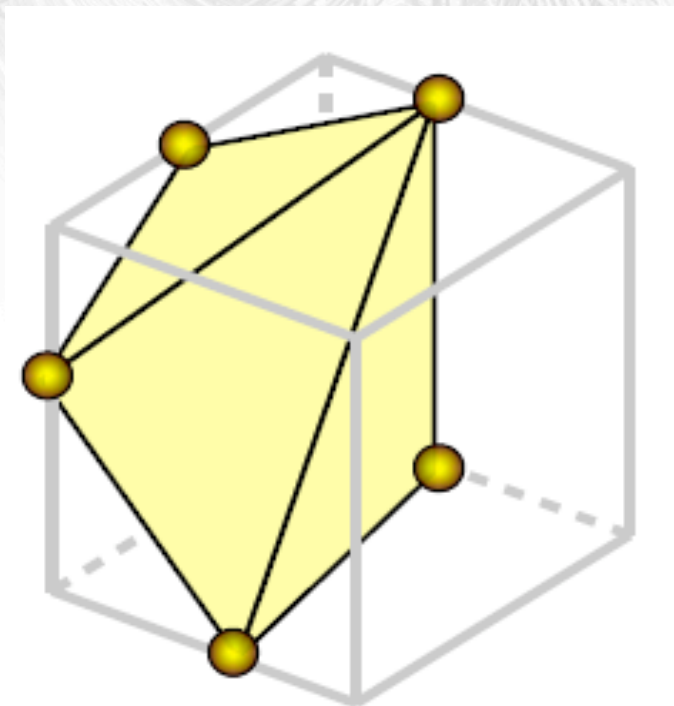

Important Observation:

Each triangle generated by MC has vertices only over active edges. Therefore, it **does not** generate arbitrary triangles

Triangle Quality of Marching Cubes

- Look at each triangle individually

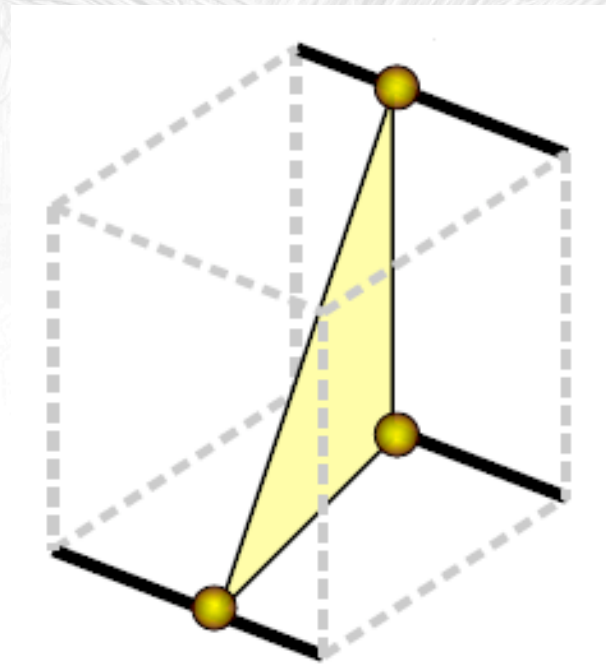
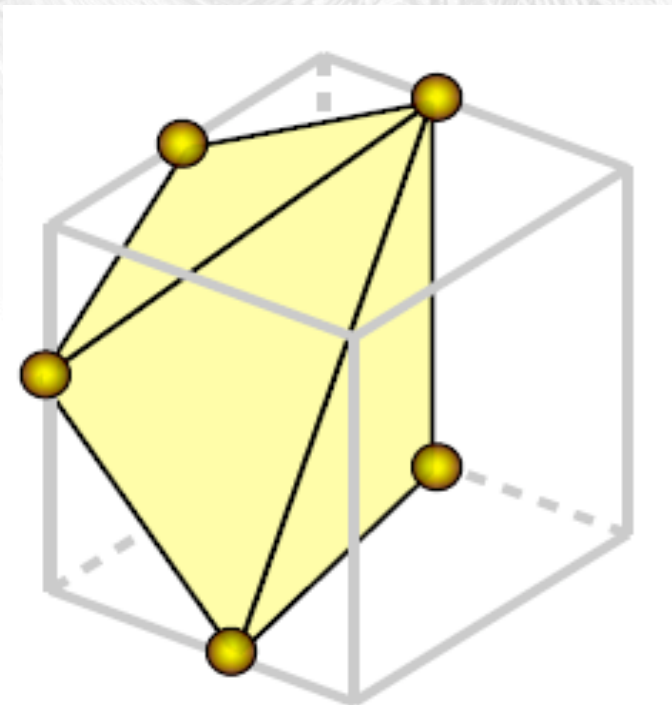

Important Observation:

Each triangle generated by MC has vertices only over active edges. Therefore, it **does not** generate arbitrary triangles

Triangle Quality of Marching Cubes

- Look at each triangle individually

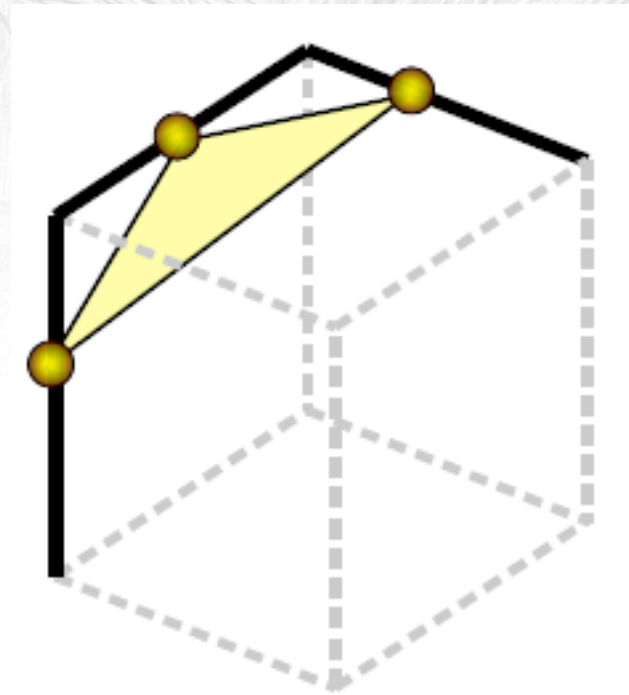
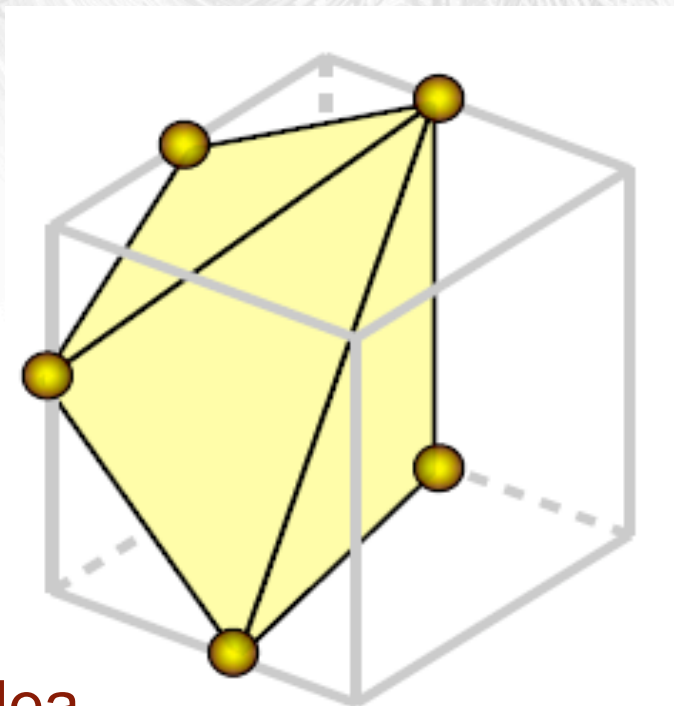

Idea

Since three **active edges** define a triangle, we could evaluate all possible triangles generated by such **configuration**

Triangle Quality of Marching Cubes

- Look at each triangle individually

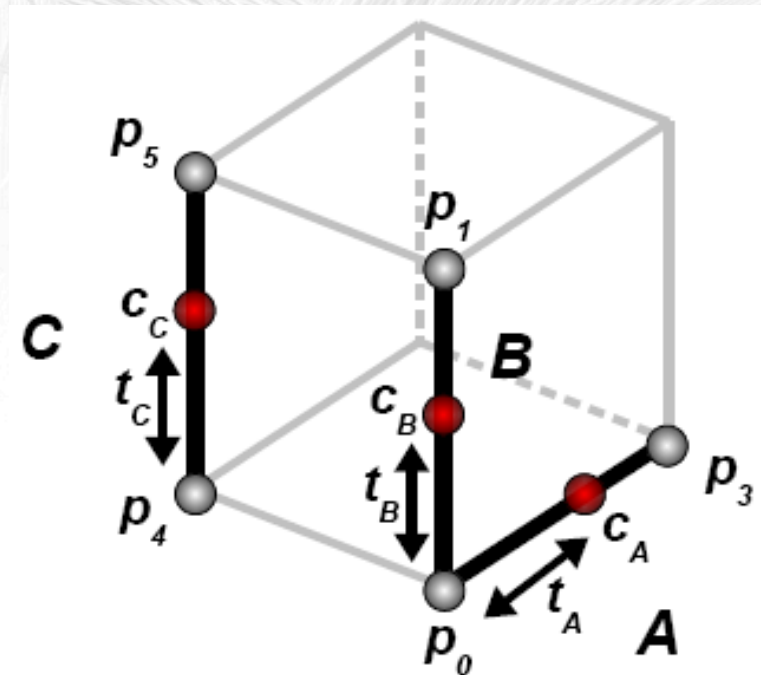
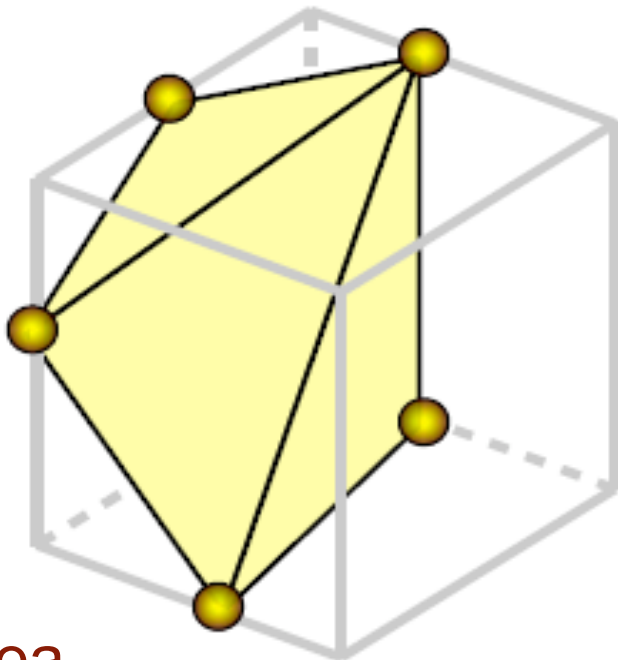

Idea

Since three **active edges** define a triangle, we could evaluate all possible triangles generated by such **configuration**

Triangle Quality of Marching Cubes

- Look at each triangle individually

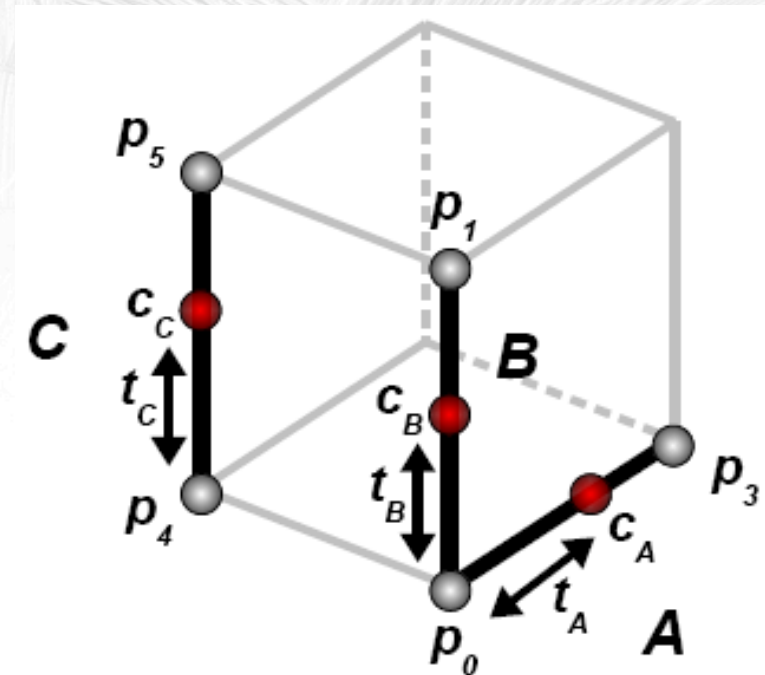
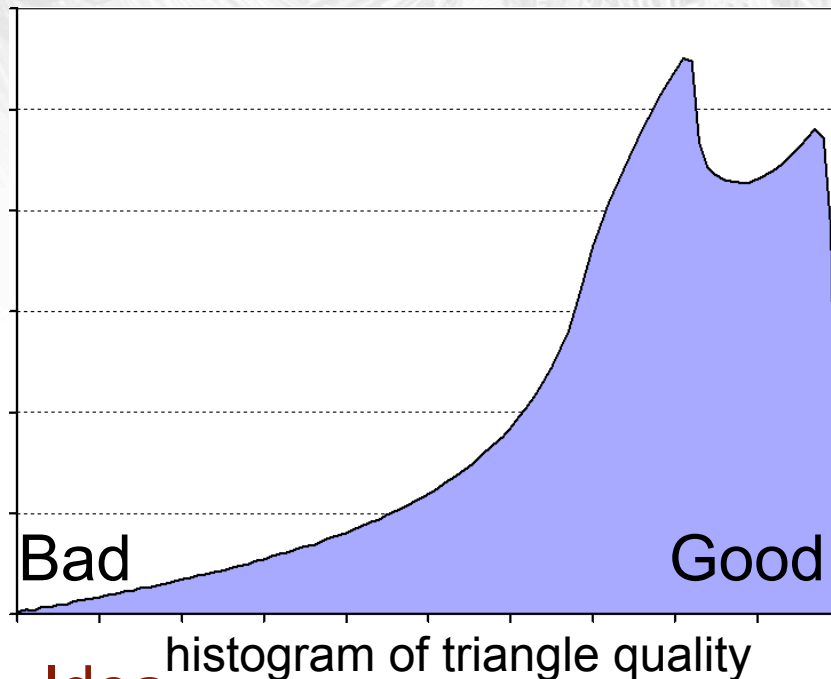

Idea

Since three **active edges** define a triangle, we could evaluate all possible triangles generated by such **configuration**

Triangle Quality of Marching Cubes

- Several conclusions can be derived

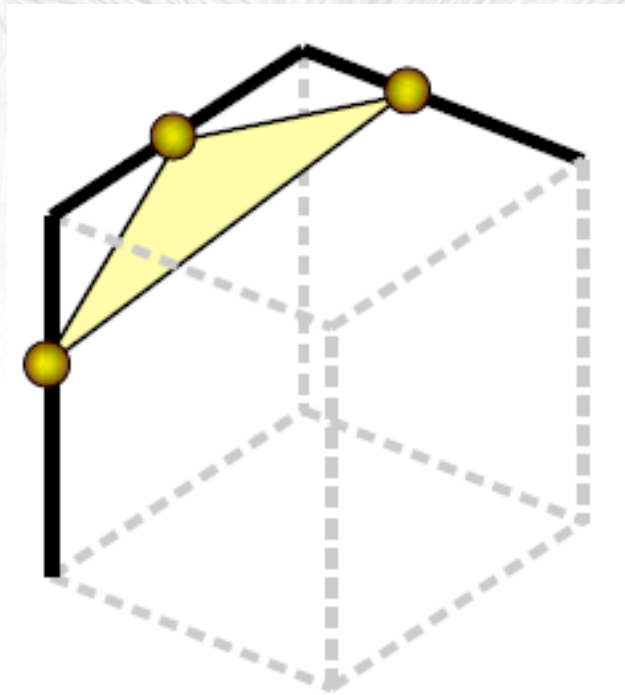
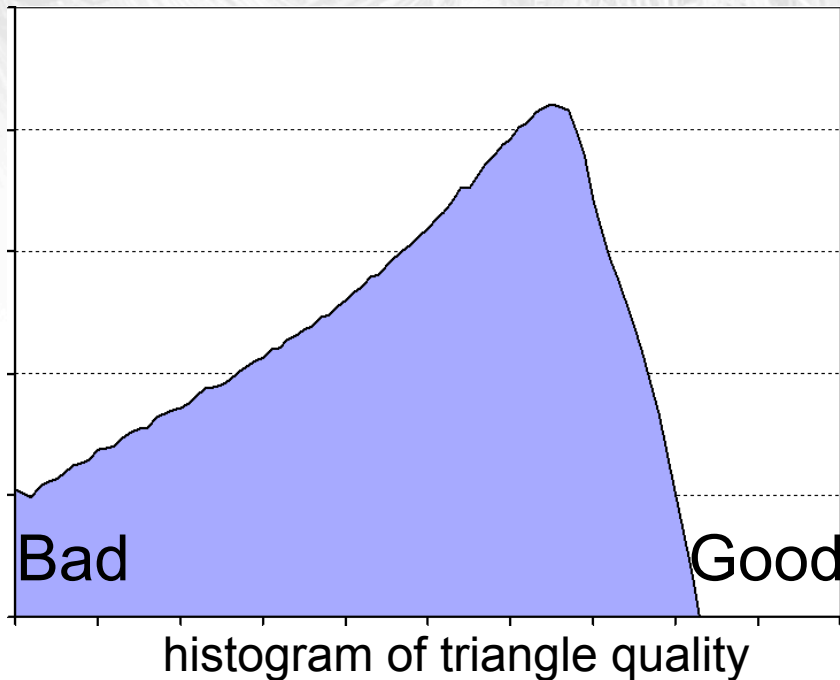

Interesting Observation

This configuration is responsible for the worst triangles of MC !!!

Triangle Quality of Marching Cubes



- Other Questions to answer:
 - How many cases of edge configurations ?

Triangle Quality of Marching Cubes

- Other Questions to answer:
 - How many cases of edge configurations ?
 - Is it similar to Marching Cubes Cases Enumeration ?

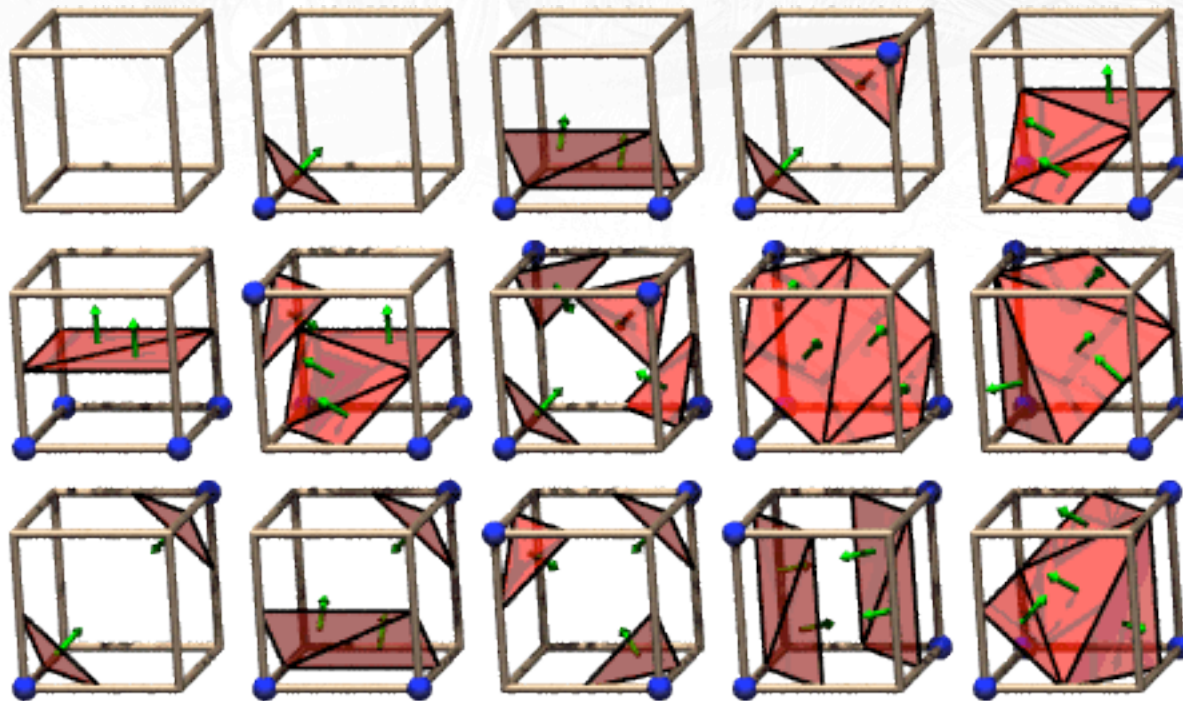

Triangle Quality of Marching Cubes

- Other Questions to answer:
 - How many cases of edge configurations ?
 - Is it similar to Marching Cubes Cases Enumeration ? **YES, but at edge level**

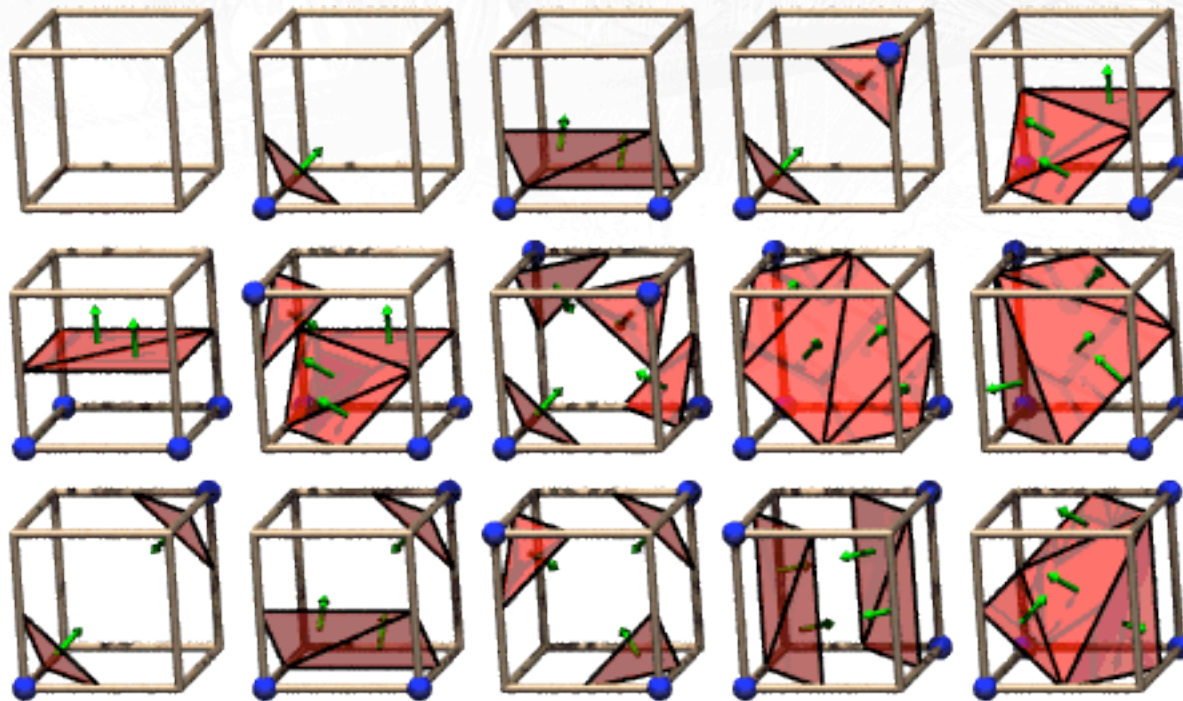

Outline



- Motivation
- **Edge Groups in Cubic Cells**
- Improving Triangle Quality Based on Edge Groups
- Results
- Conclusions

Edge Groups in Cubic Cells



- Counting Cases in MC
 - [Lorensen and Cline 87] 15 cases based on inspection
 - [Nielson et al 2002] 23 cases by rotation only
 - [Banks et al 2004] formal proof using group theory

Edge Groups in Cubic Cells



- Counting Cases in MC
 - [Lorensen and Cline 87] 15 cases based on inspection
 - [Nielson et al 2002] 23 cases by rotation only
 - [Banks et al 2004] formal proof using group theory
- Counting Cases in Edge Configurations:
 - Edge configuration (e_0, e_1, e_2) : 3 different edges of the cube
 - **Edge (Symmetry) Group**: collection of edge configurations that can be transformed into another by symmetry transformations (e.g. rotations and improper reflections)

Edge Groups in Cubic Cells

- Counting Cases in MC
 - [Lorensen and Cline 87] 15 cases based on inspection
 - [Nielson et al 2002] 23 cases by rotation only
 - [Banks et al 2004] formal proof using group theory
- Counting Cases in Edge Configurations:
 - Edge configuration (e_0, e_1, e_2) : 3 different edges of the cube
 - **Edge (Symmetry) Group**: collection of edge configurations that can be transformed into another by symmetry transformations (e.g. rotations and improper reflections)

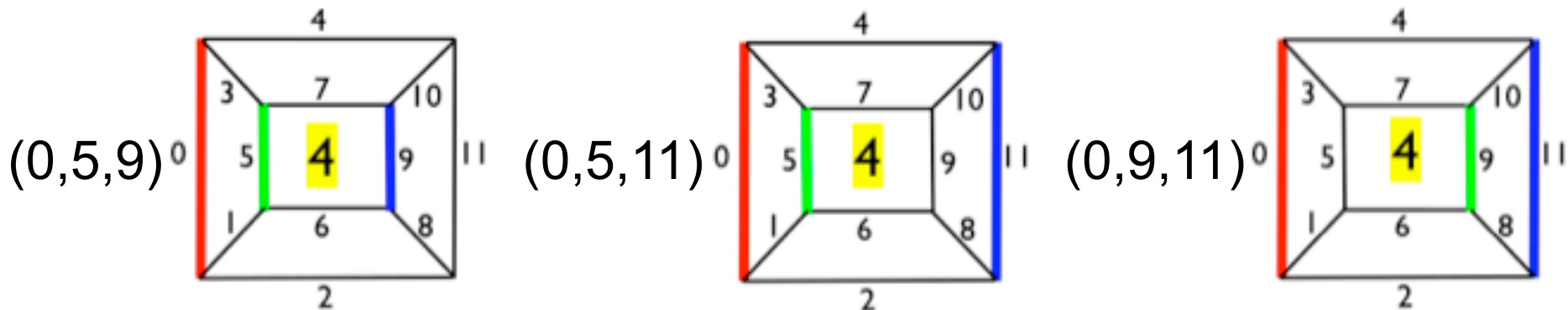

Counting Cases in Edge Groups



- True to the original Marching Cubes paper, we first did it by inspection too
- How ?

Edge Groups in the MC table

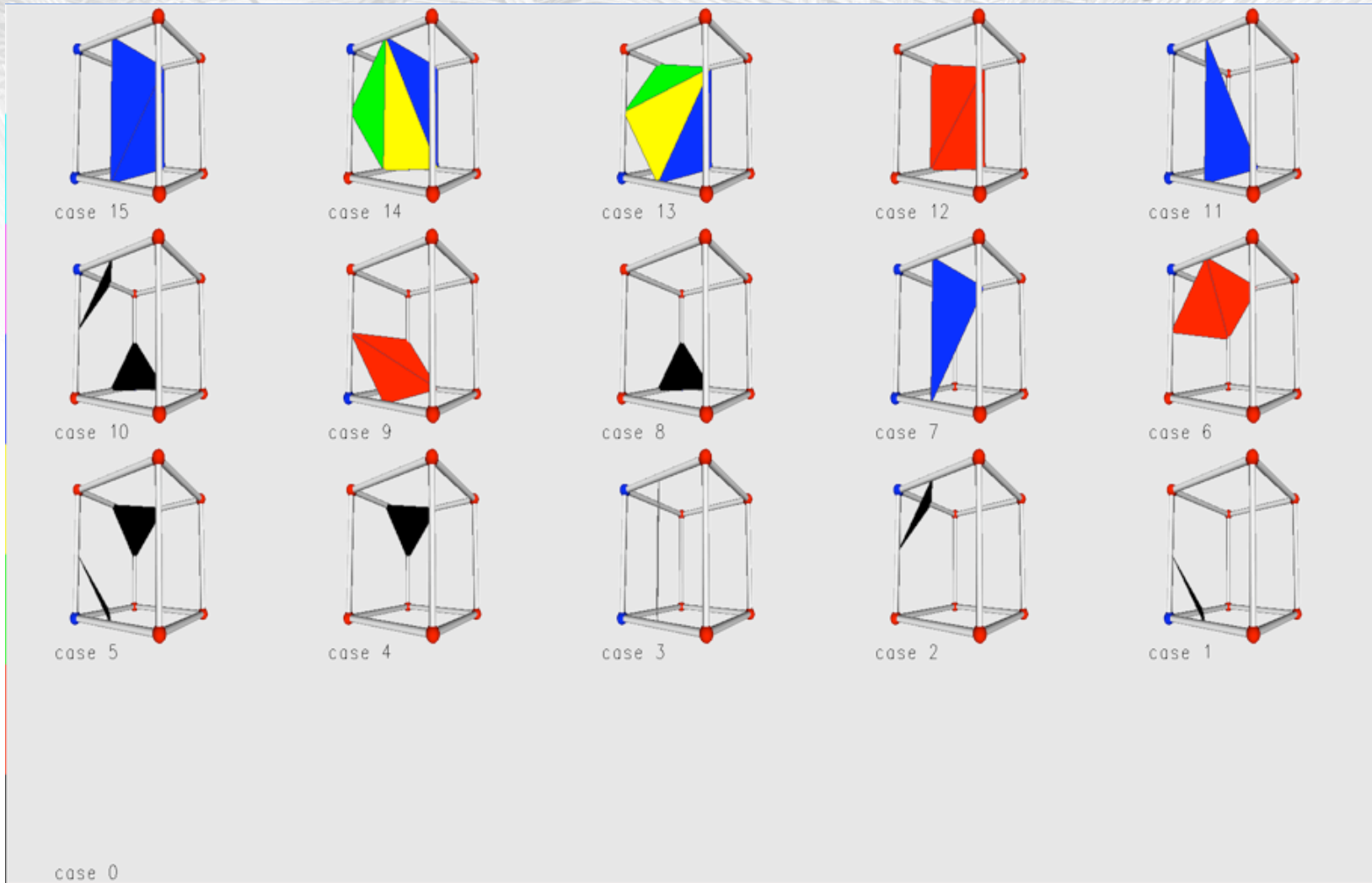

Edge Groups in the MC table

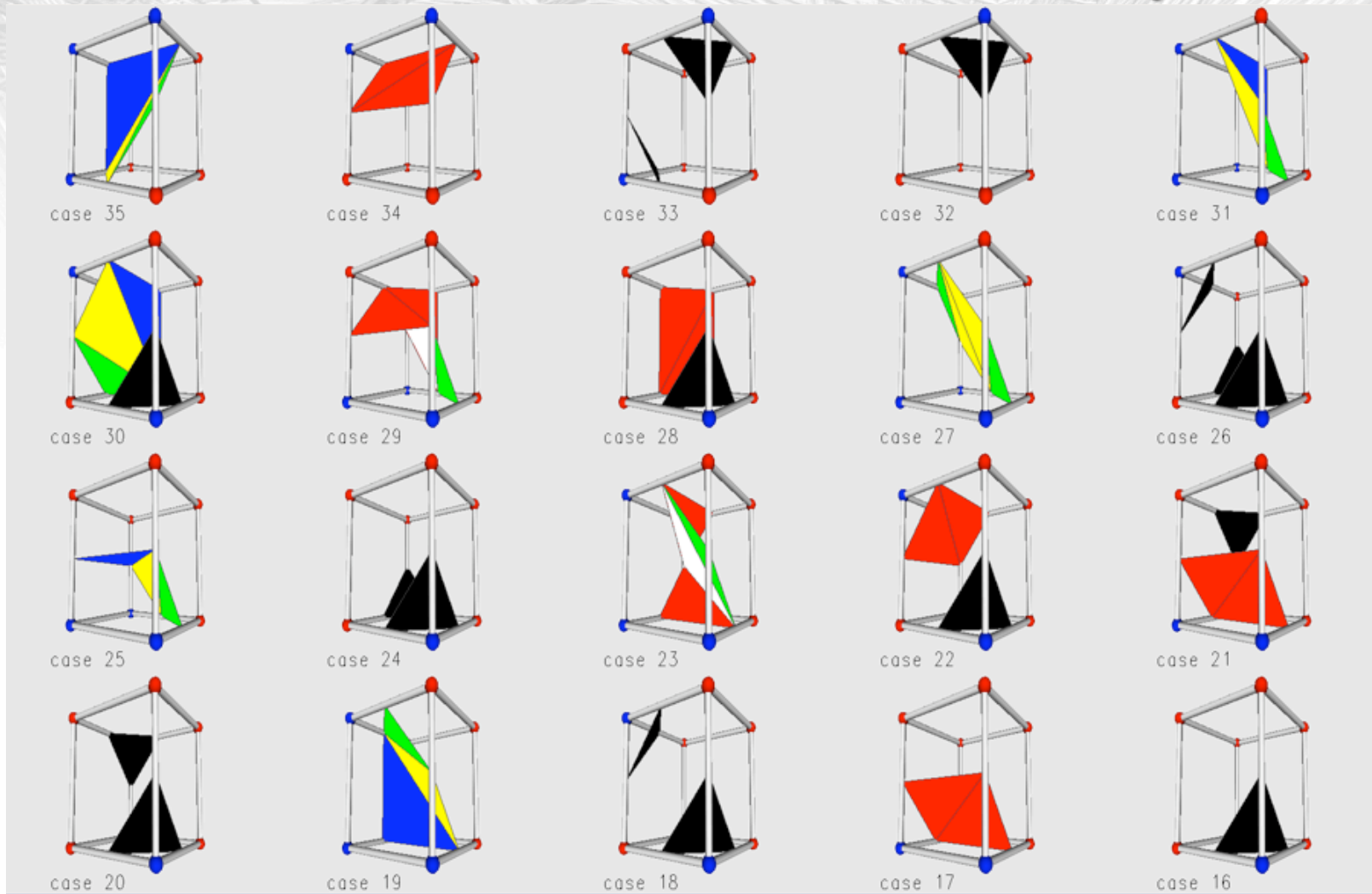

Edge Groups in the MC table

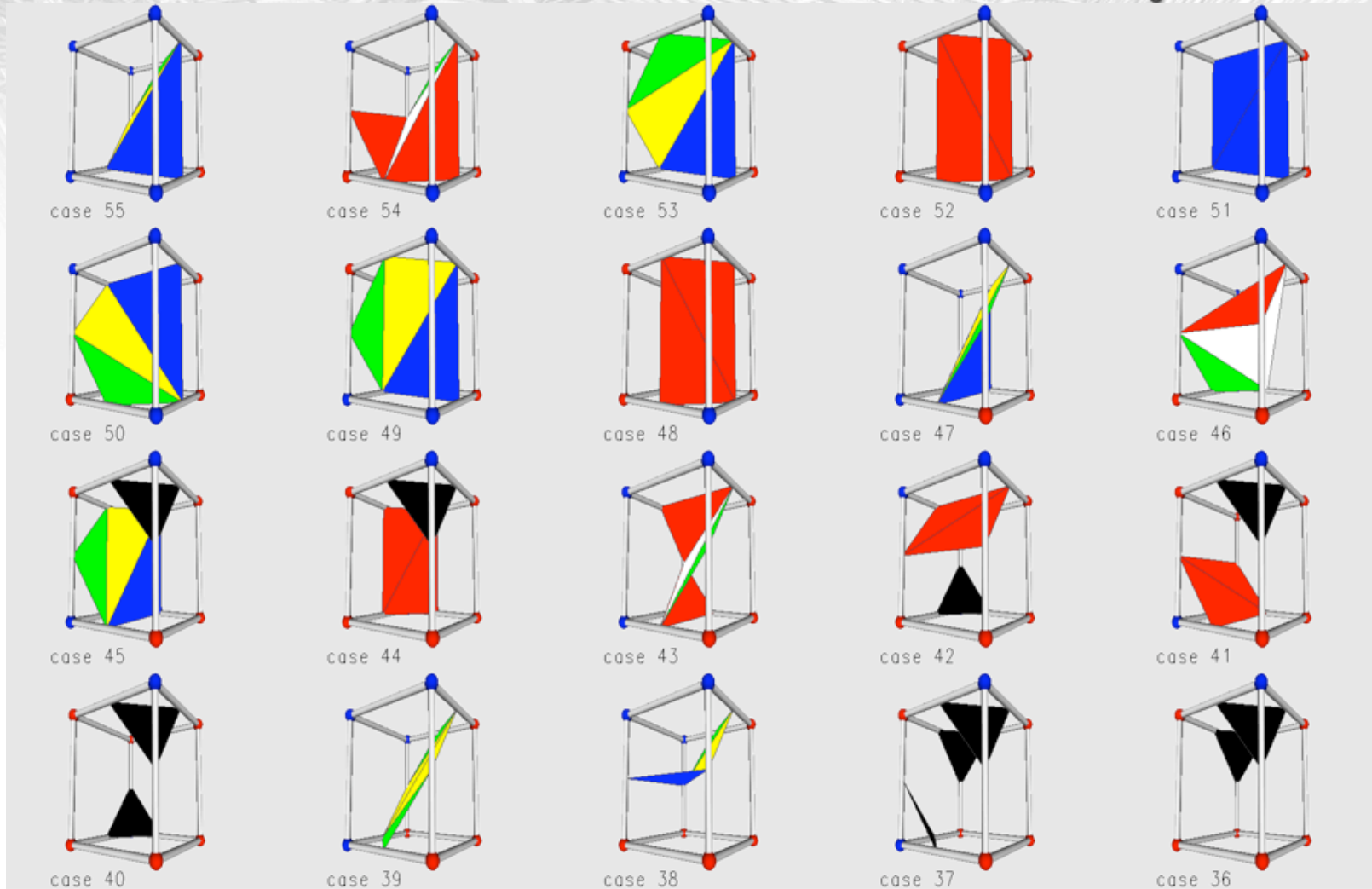

Edge Groups in the MC table

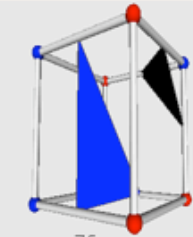

case 75

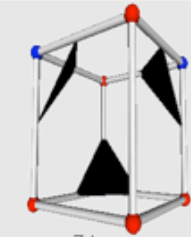

case 74

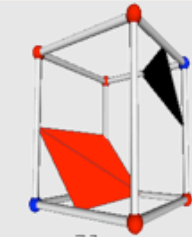

case 73

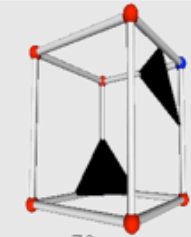

case 72

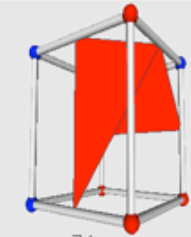

case 71

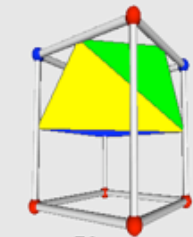

case 70

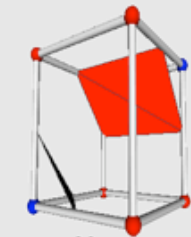

case 69

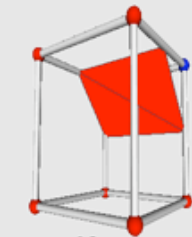

case 68

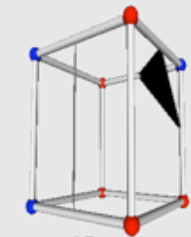

case 67

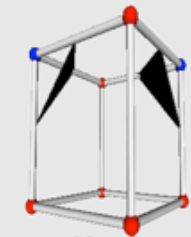

case 66

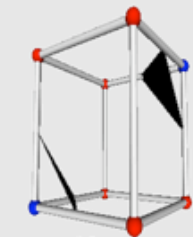

case 65

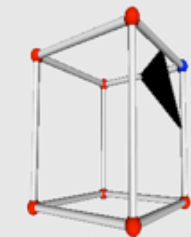

case 64

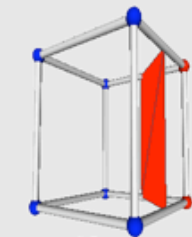

case 63

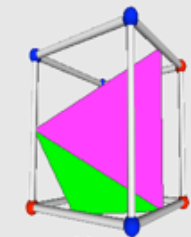

case 62

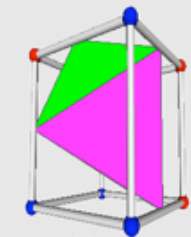

case 61

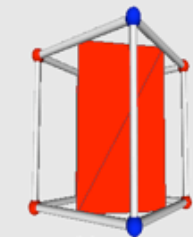

case 60

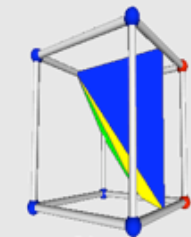

case 59

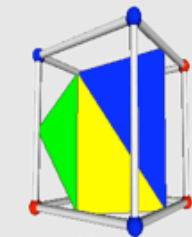

case 58

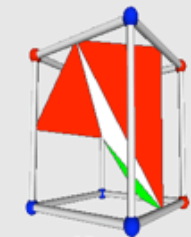

case 57

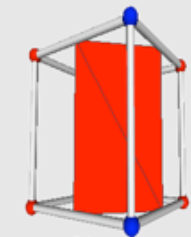

case 56

Edge Groups in the MC table

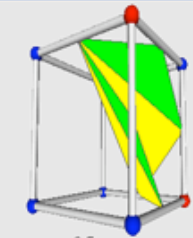

case 95

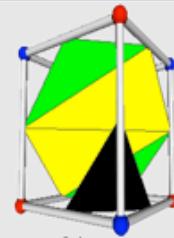

case 94

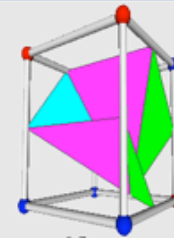

case 93

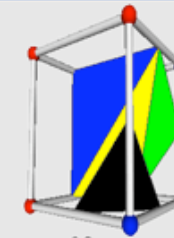

case 92

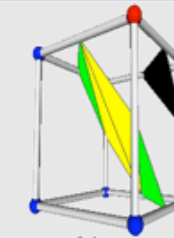

case 91

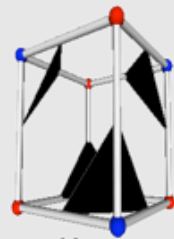

case 90

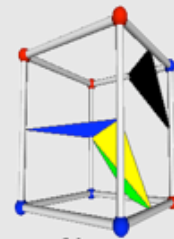

case 89

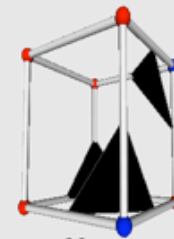

case 88

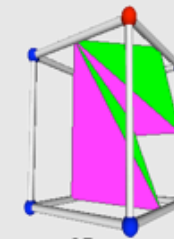

case 87

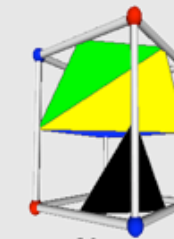

case 86

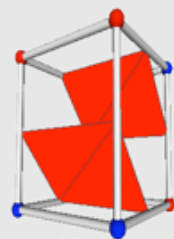

case 85

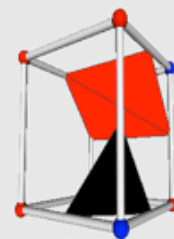

case 84

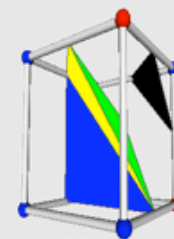

case 83

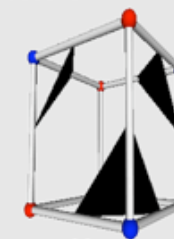

case 82

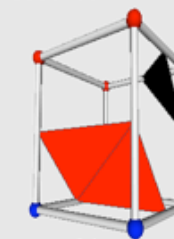

case 81

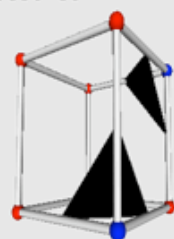

case 80

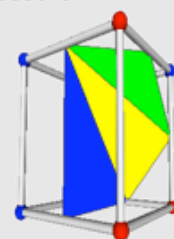

case 79

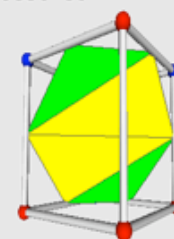

case 78

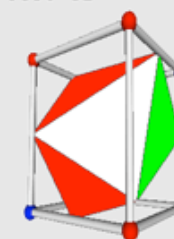

case 77

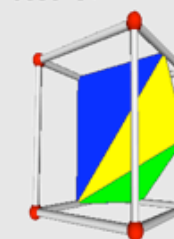

case 76

Edge Groups in the MC table

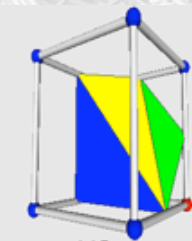

case 115

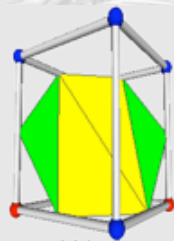

case 114

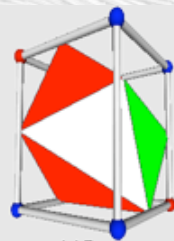

case 113

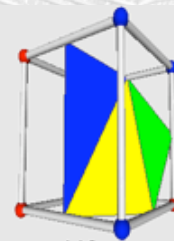

case 112

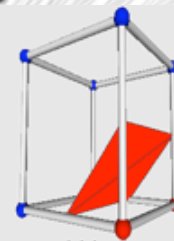

case 111

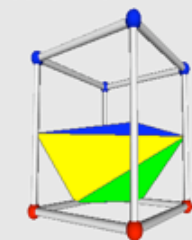

case 110

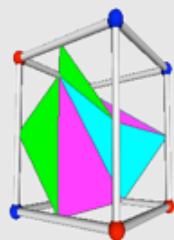

case 109

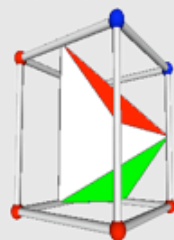

case 108

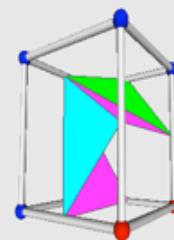

case 107

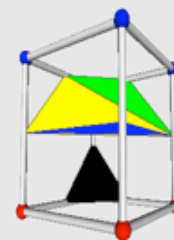

case 106

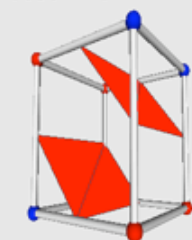

case 105

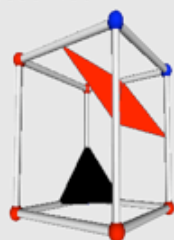

case 104

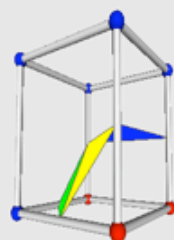

case 103

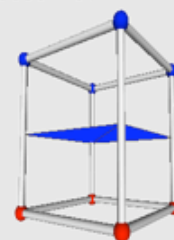

case 102

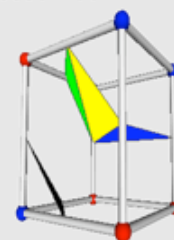

case 101

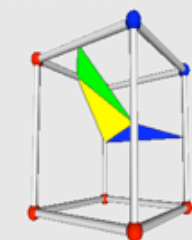

case 100

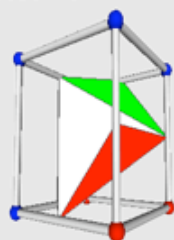

case 99

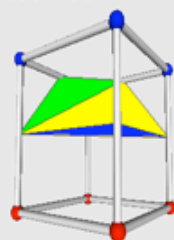

case 98

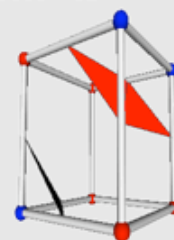

case 97

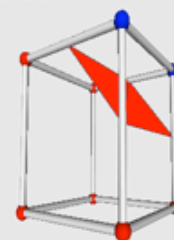

case 96

Edge Groups in the MC table

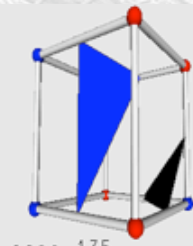

case 135

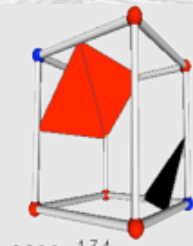

case 134

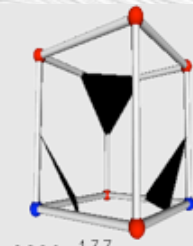

case 133

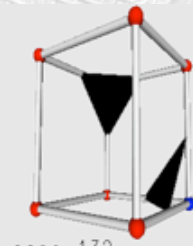

case 132

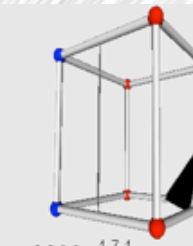

case 131

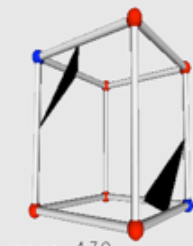

case 130

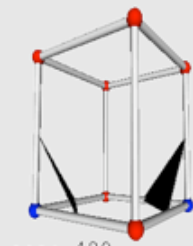

case 129

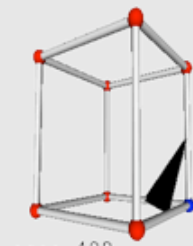

case 128

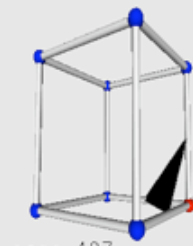

case 127

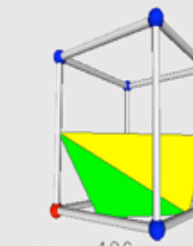

case 126

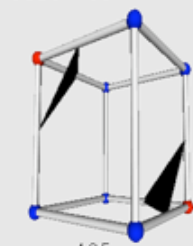

case 125

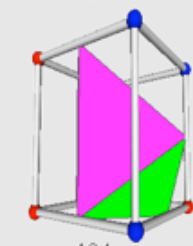

case 124

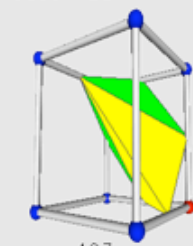

case 123

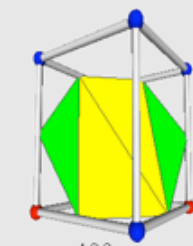

case 122

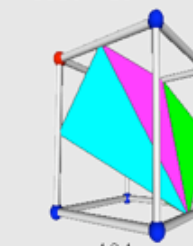

case 121

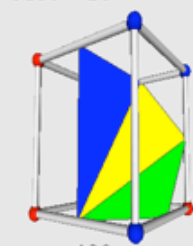

case 120

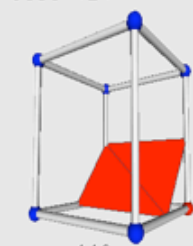

case 119

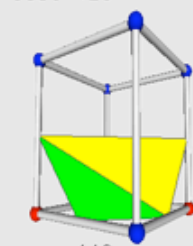

case 118

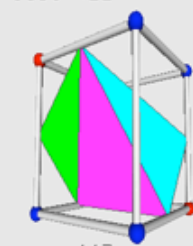

case 117

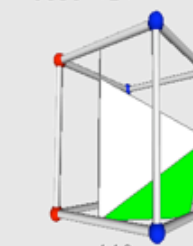

case 116

Edge Groups in the MC table

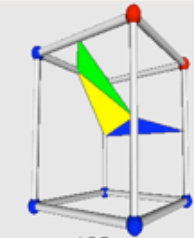

case 155

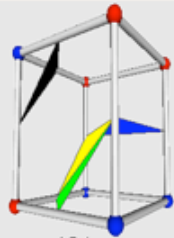

case 154

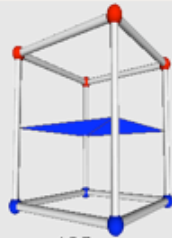

case 153

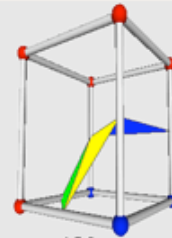

case 152

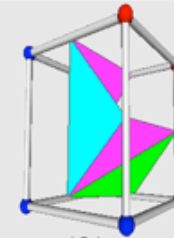

case 151

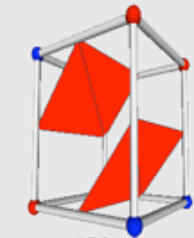

case 150

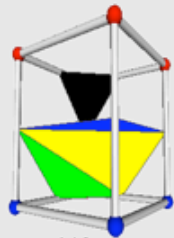

case 149

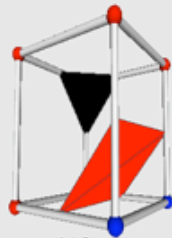

case 148

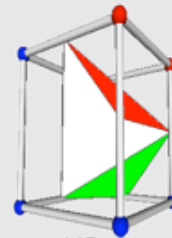

case 147

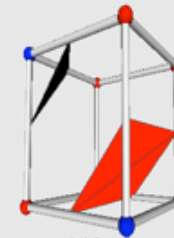

case 146

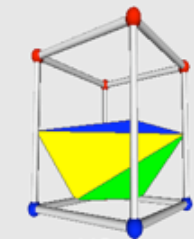

case 145

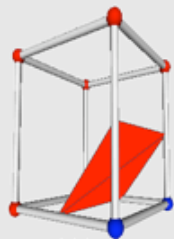

case 144

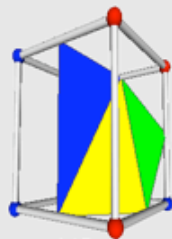

case 143

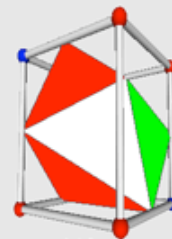

case 142

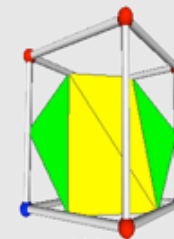

case 141

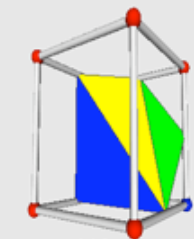

case 140

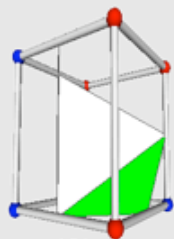

case 139

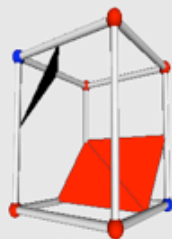

case 138

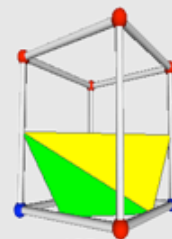

case 137

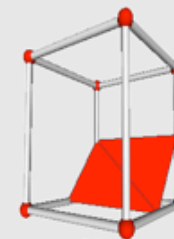

case 136

Edge Groups in the MC table

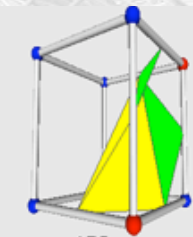

case 175

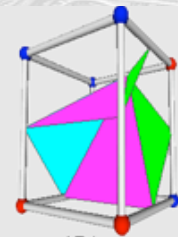

case 174

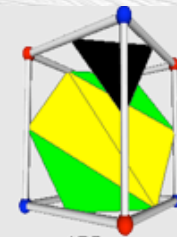

case 173

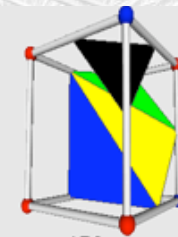

case 172

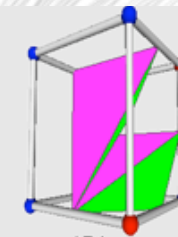

case 171

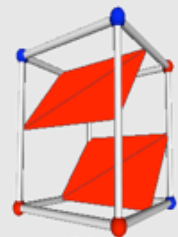

case 170

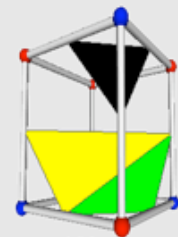

case 169



case 168

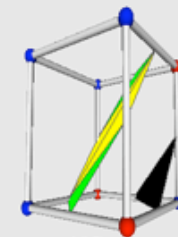

case 167

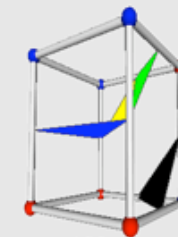

case 166

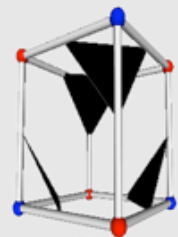

case 165

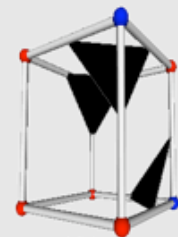

case 164

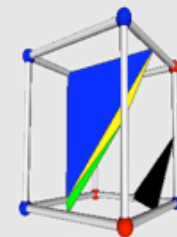

case 163

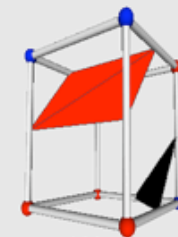

case 162

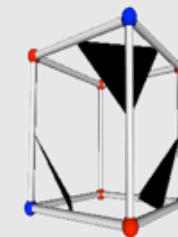

case 161

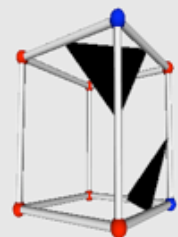

case 160

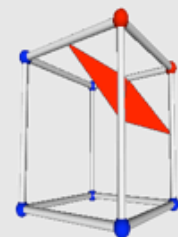

case 159

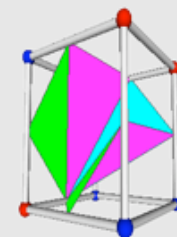

case 158

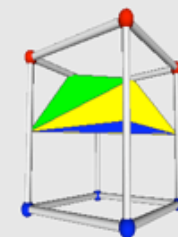

case 157

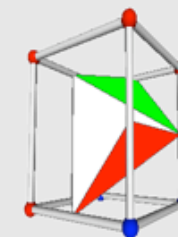

case 156

Edge Groups in the MC table

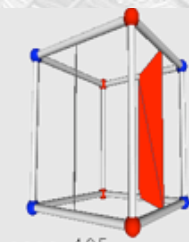

case 195

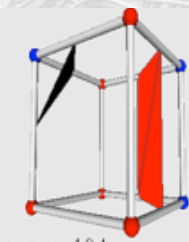

case 194

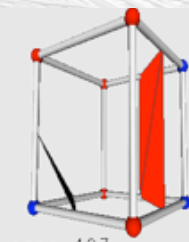

case 193

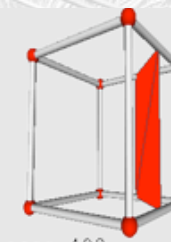

case 192

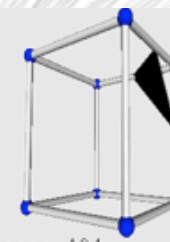

case 191

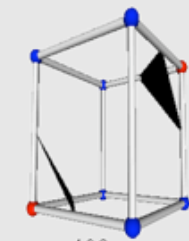

case 190

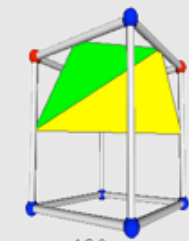

case 189

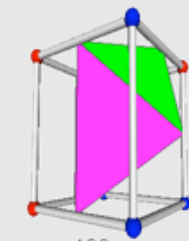

case 188

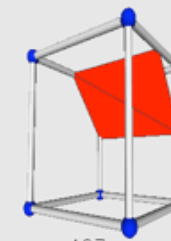

case 187

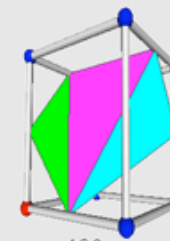

case 186

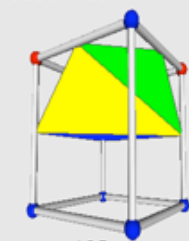

case 185

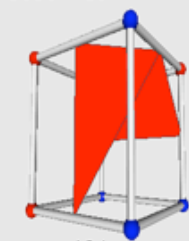

case 184

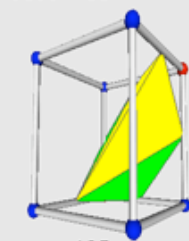

case 183

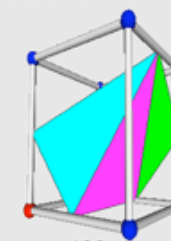

case 182

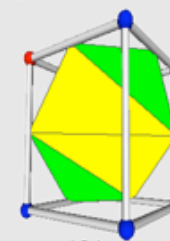

case 181

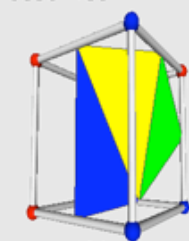

case 180

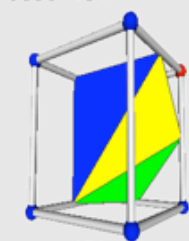

case 179

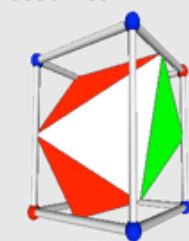

case 178

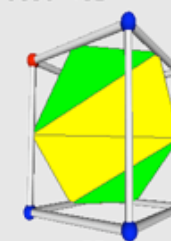

case 177



case 176

Edge Groups in the MC table

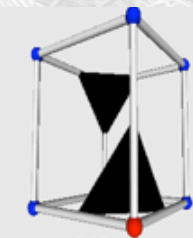

case 235

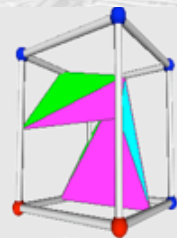

case 234

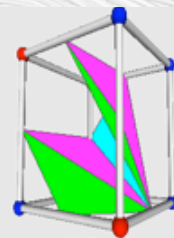

case 233

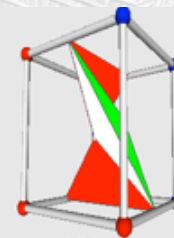

case 232

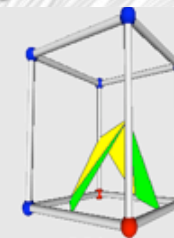

case 231

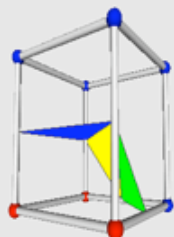

case 230

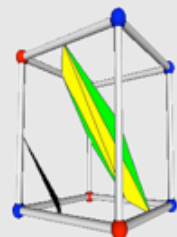

case 229

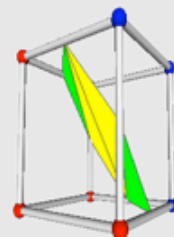

case 228

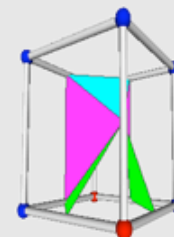

case 227



case 226

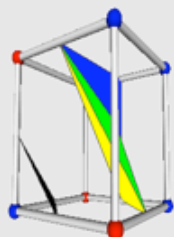

case 225

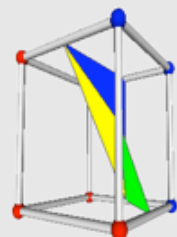

case 224

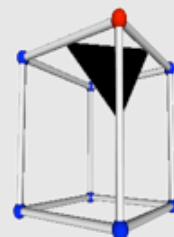

case 223

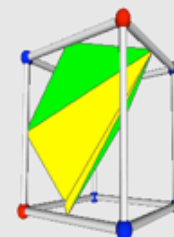

case 222

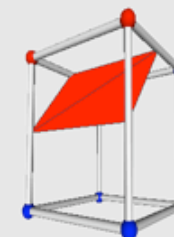

case 221

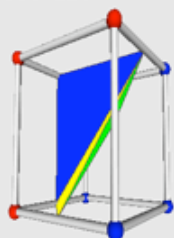

case 220

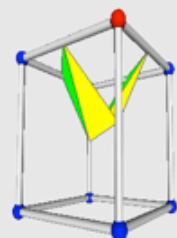

case 219

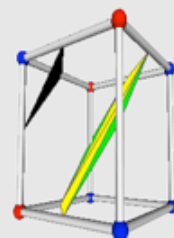

case 218

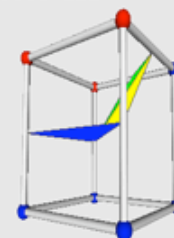

case 217

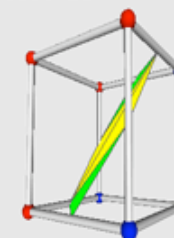

case 216

Edge Groups in the MC table

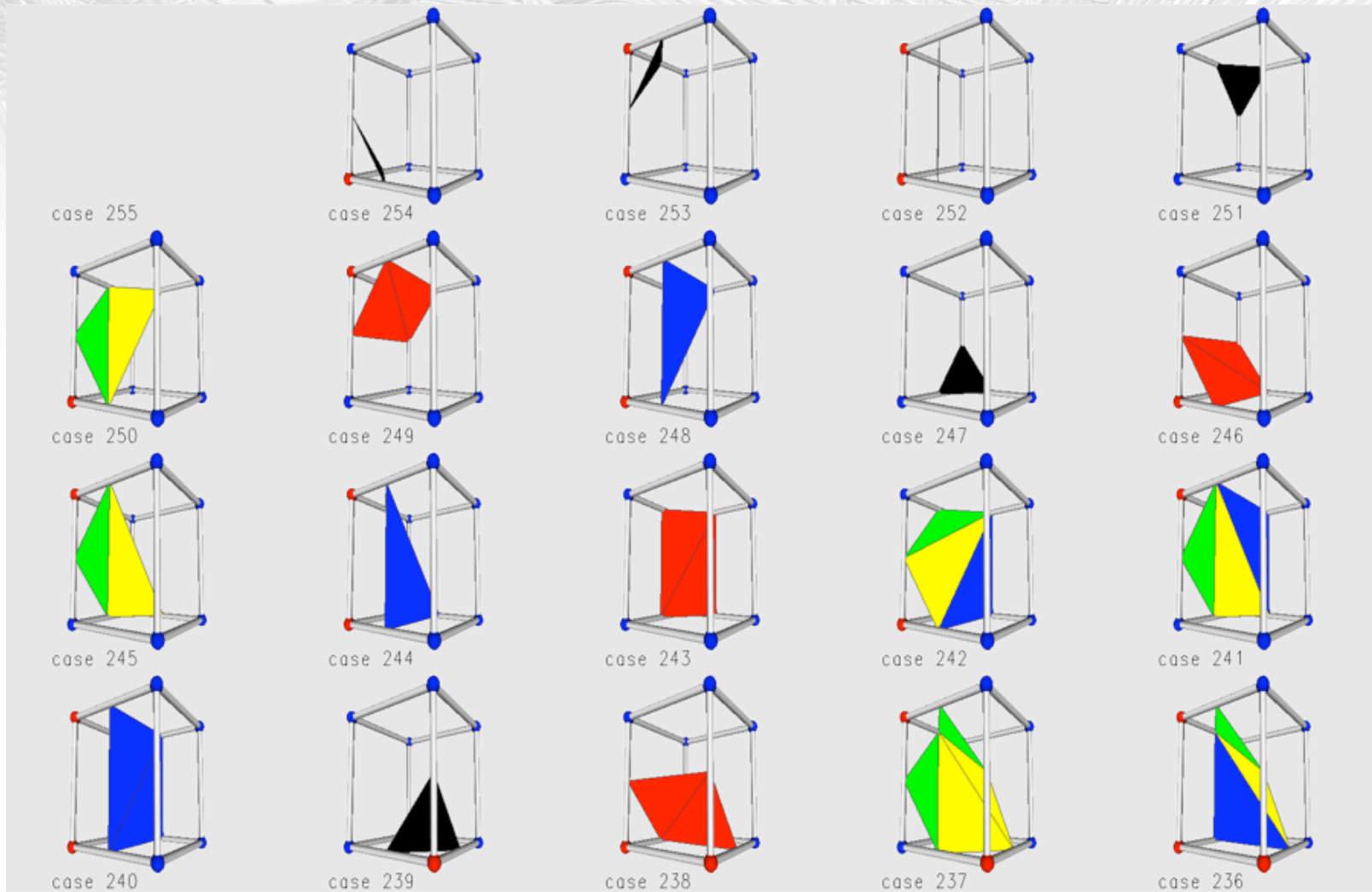

Edge Groups in the MC table

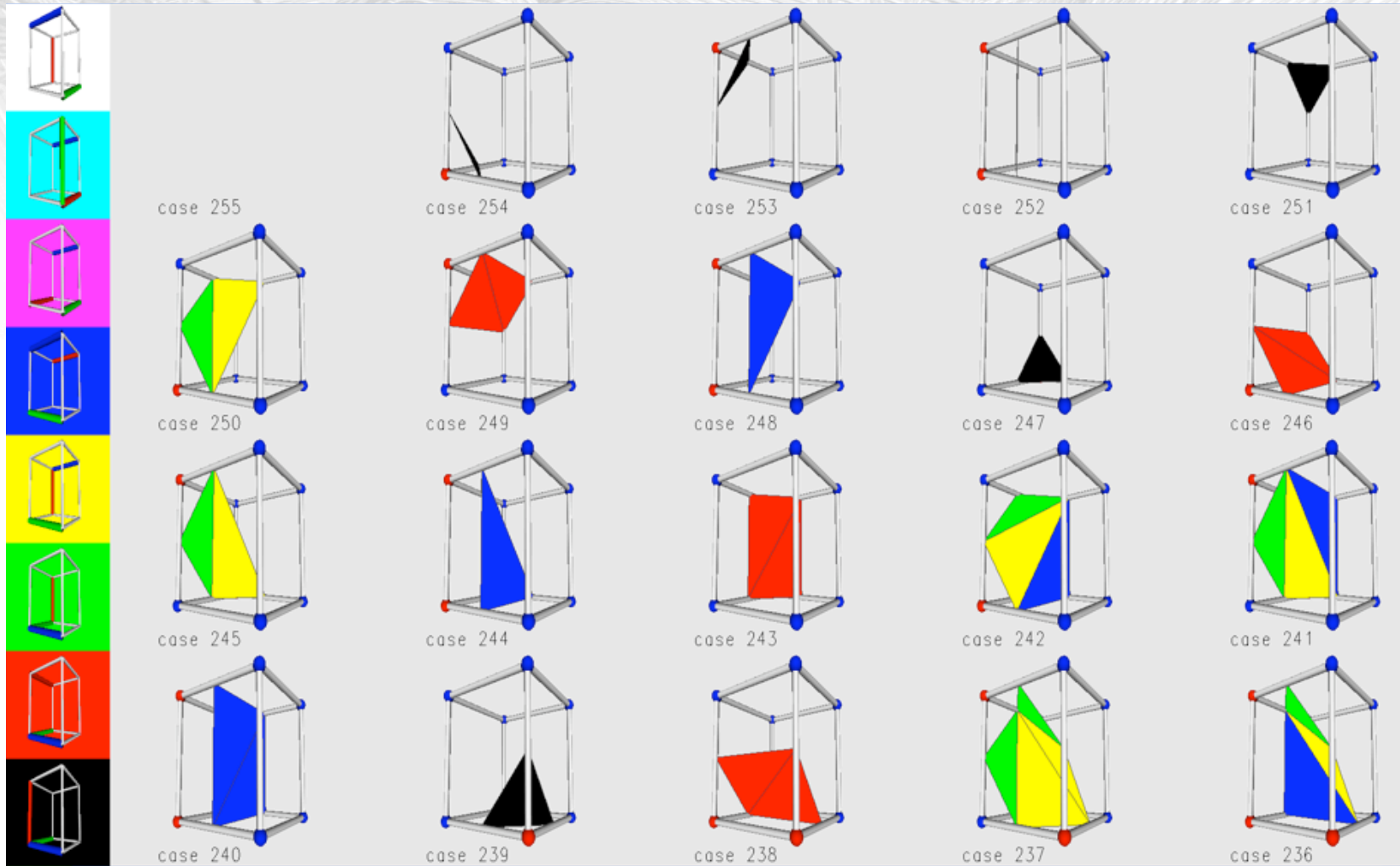

Edge Groups proof (paper)

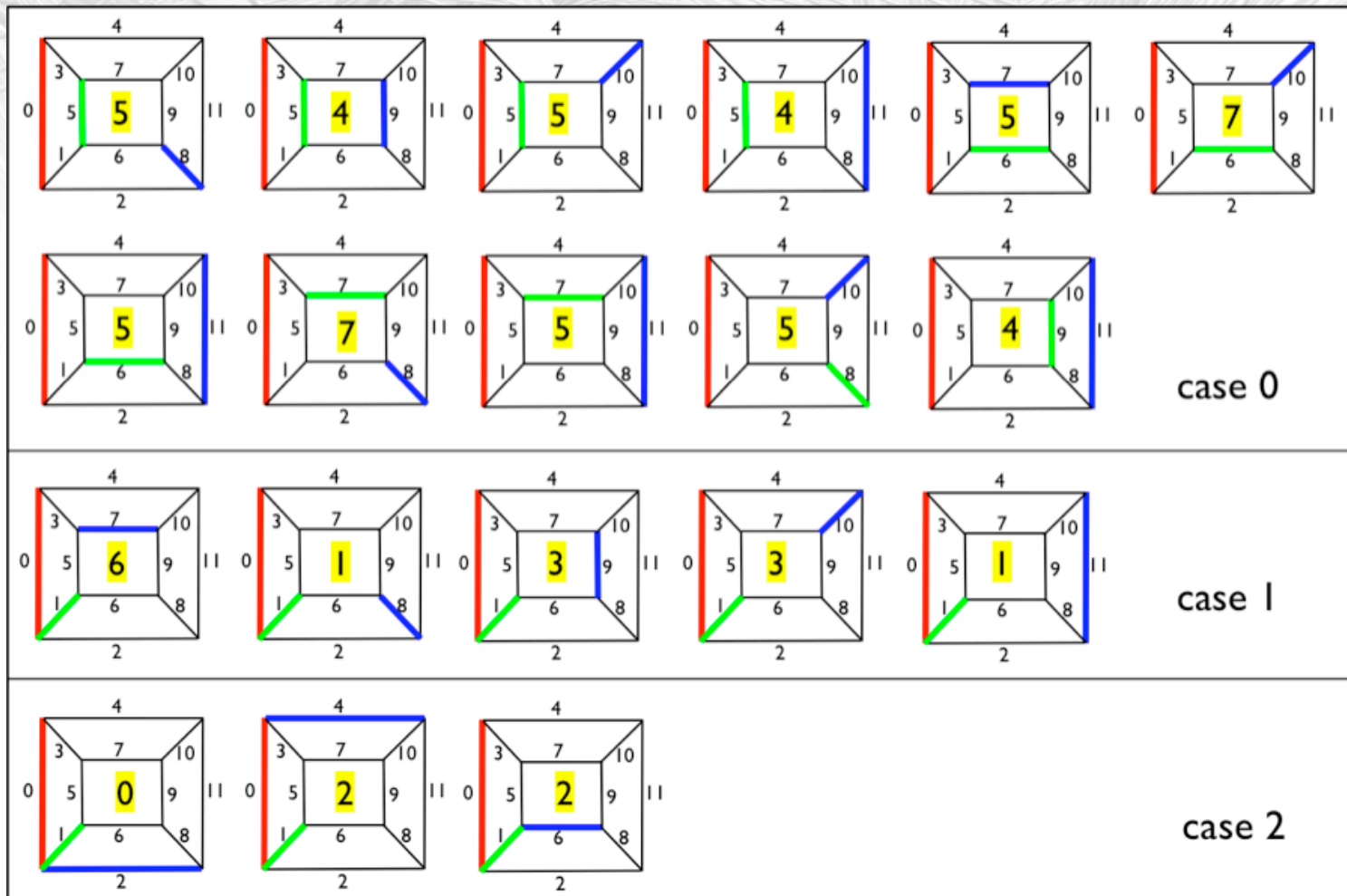

8 Edge Groups in Cubic Cells

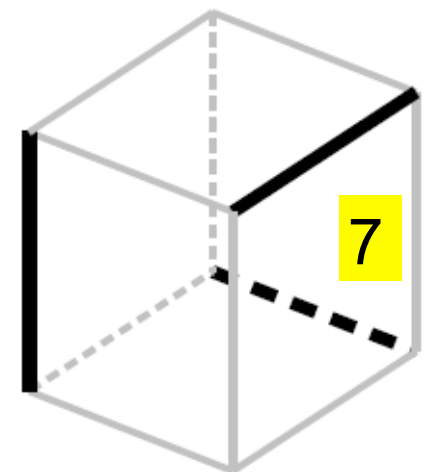
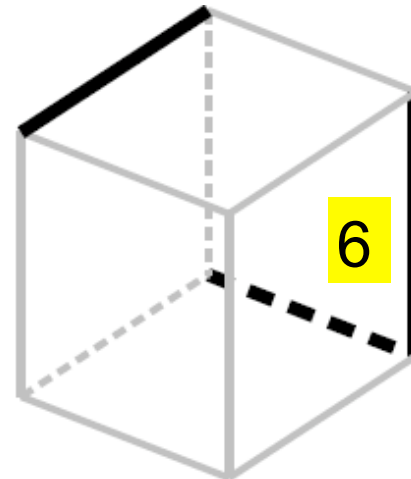
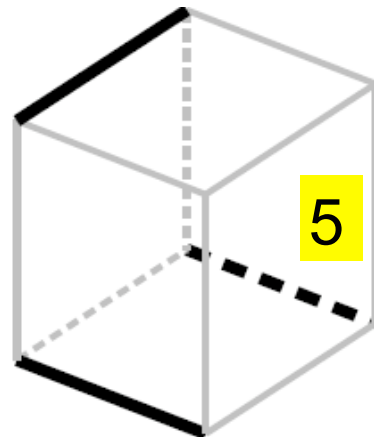
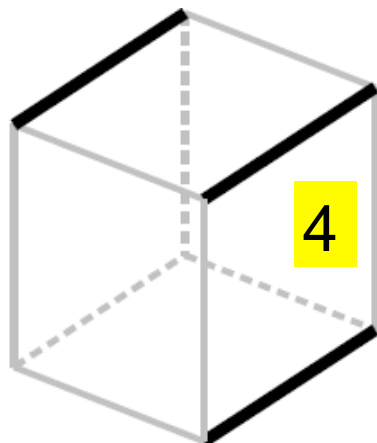
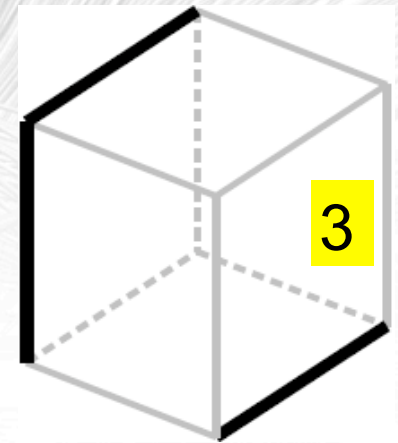
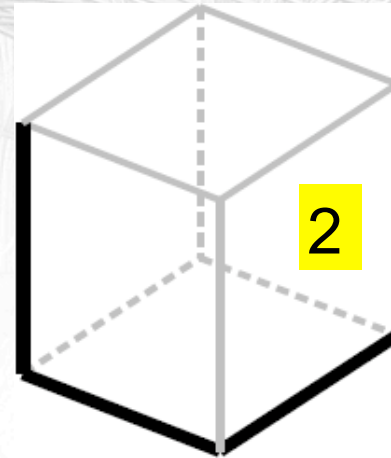
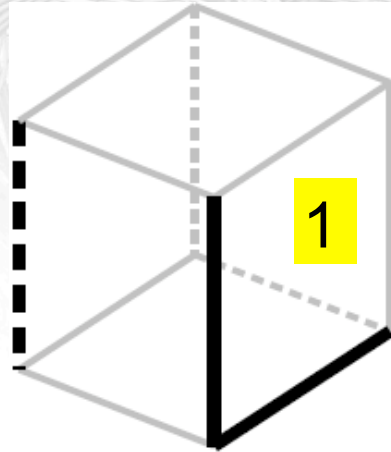
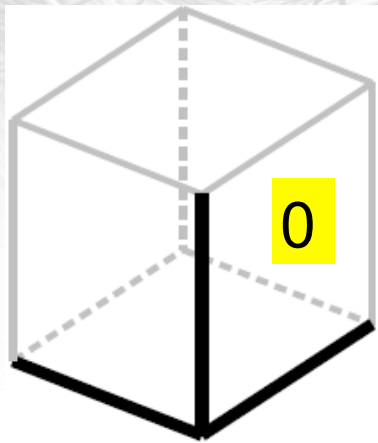

Triangle quality analysis: Worst triangle of case 4

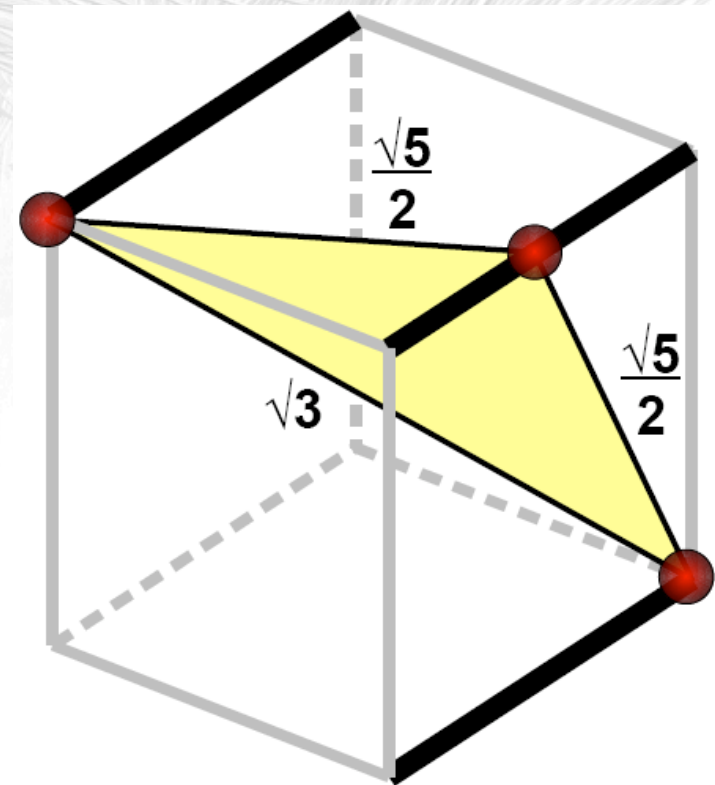
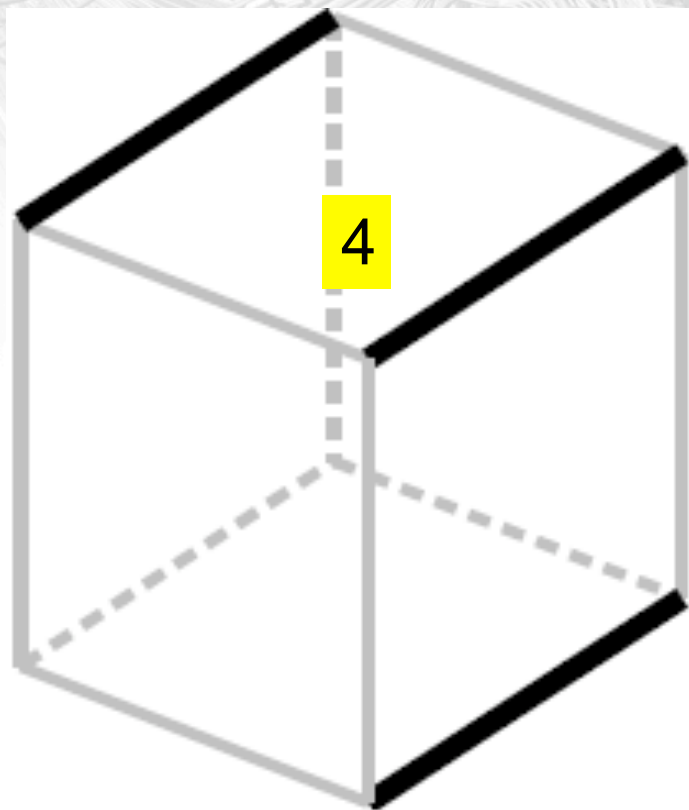

Triangle quality analysis: Worst triangle of case 6

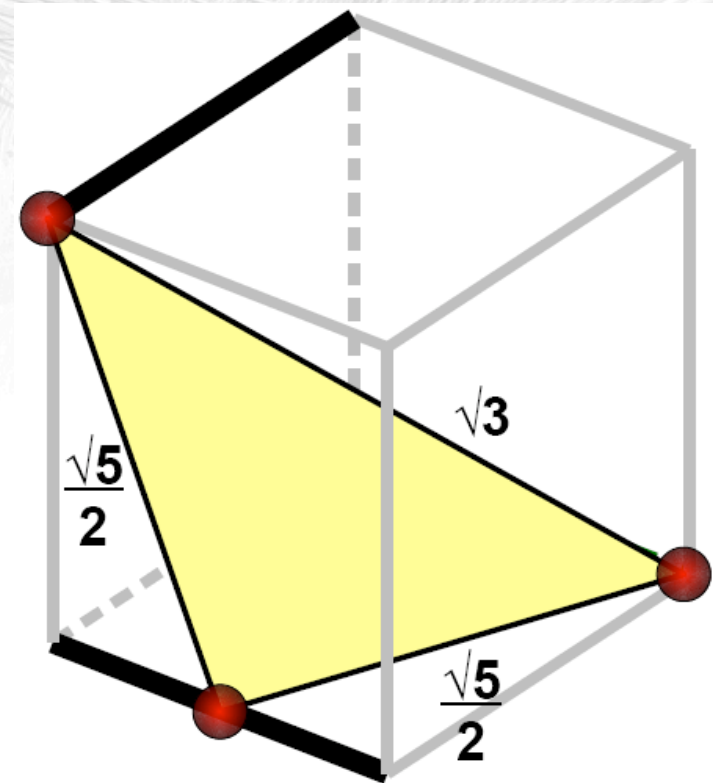
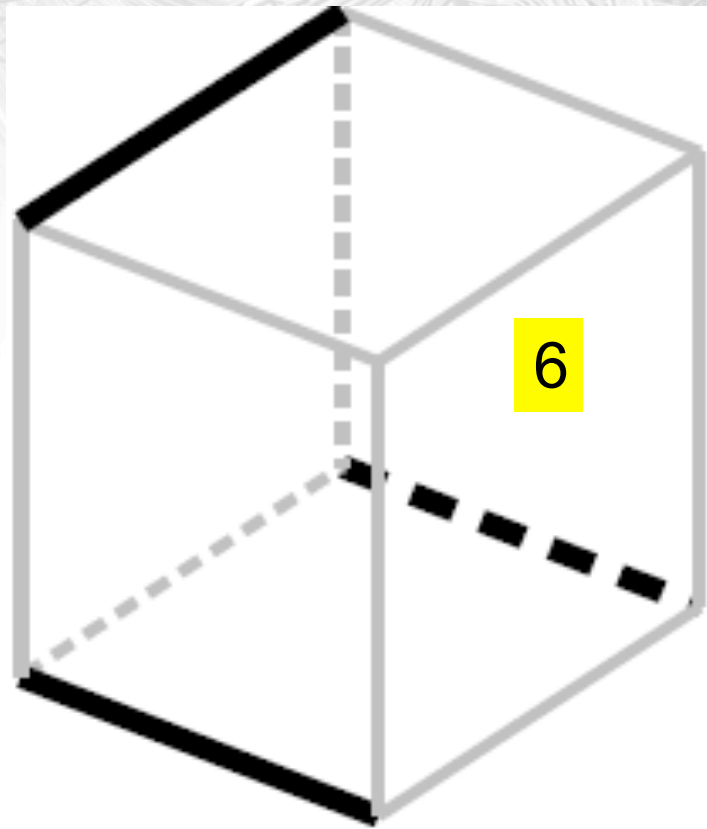



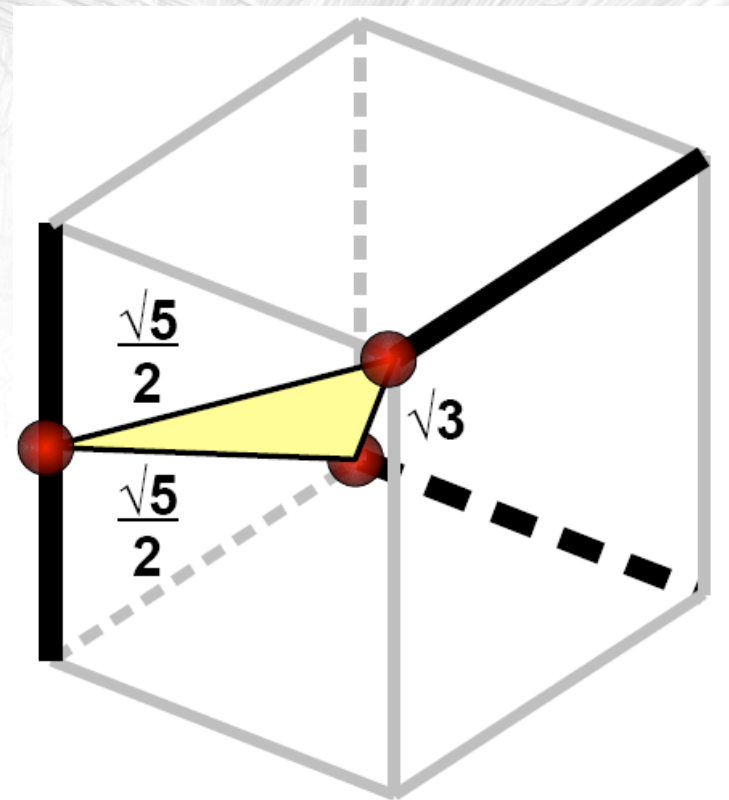
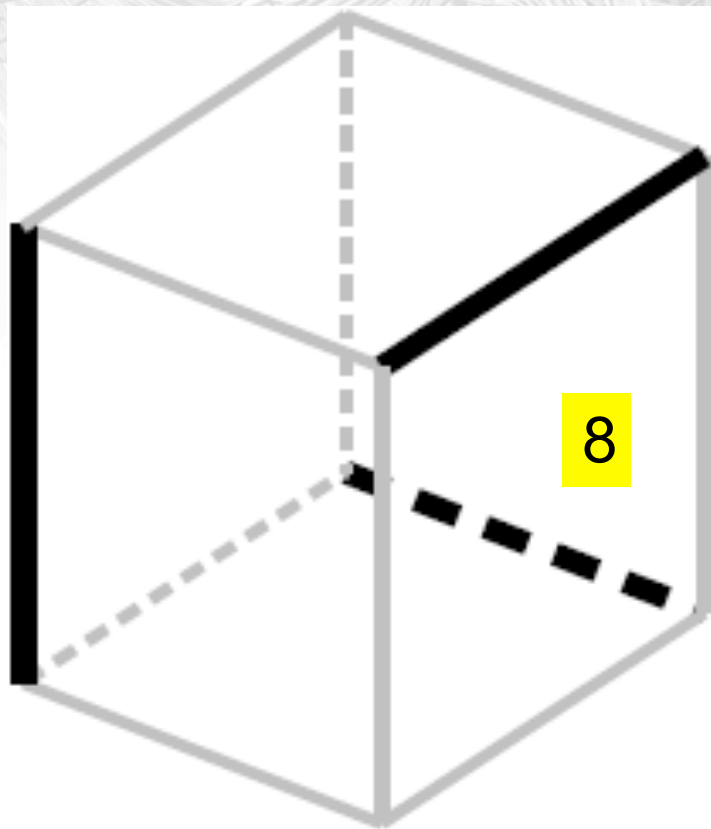

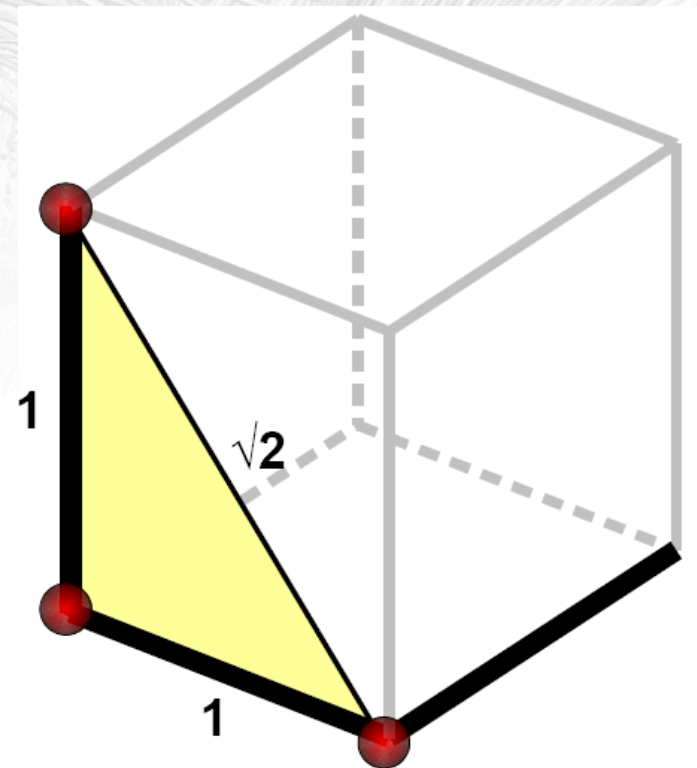
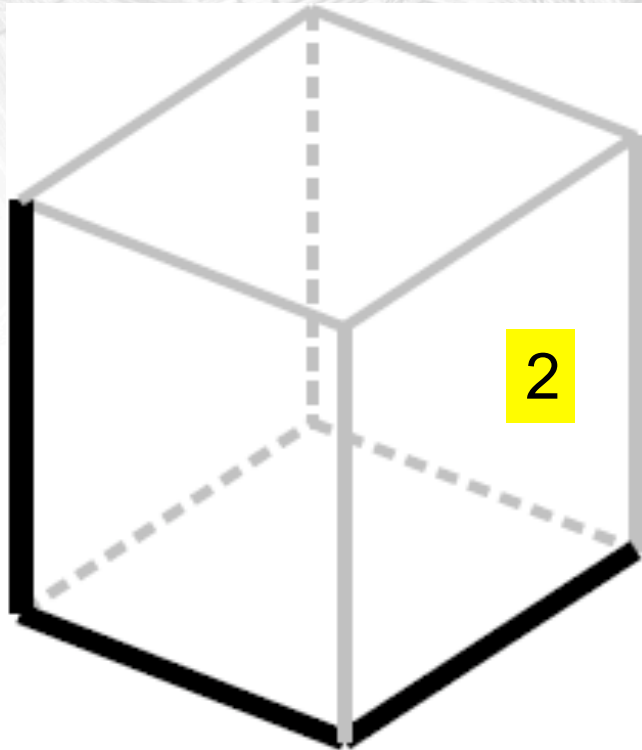

Triangle quality analysis: Worst triangle of case 8

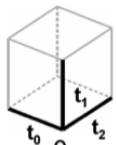
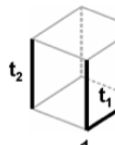
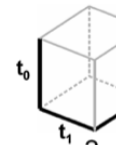
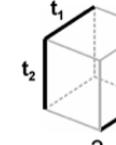
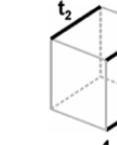
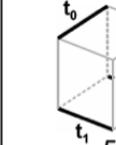

Triangle quality analysis: Best triangle of case 2

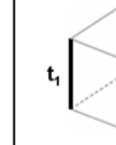
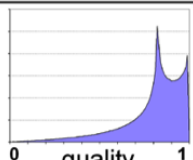
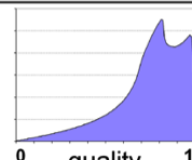

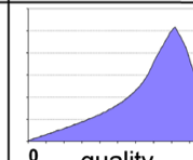
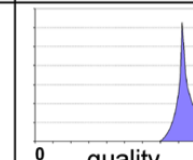
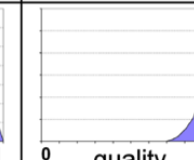
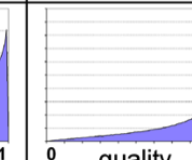
Triangle Quality Analysis: Edge Groups

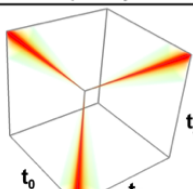
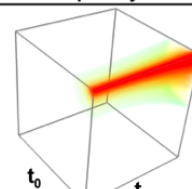
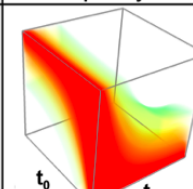
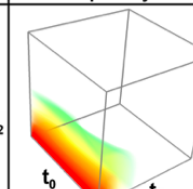
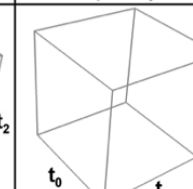
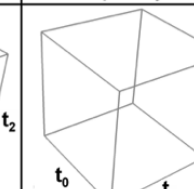
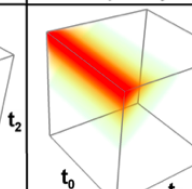
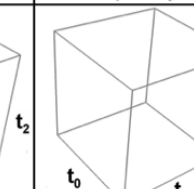
Quality	Edge Groups							
								
<i>min/max</i>	0.0/1.0	0.0/1.0	0.0/0.828	0.0/1.0	0.698/1.0	0.698/1.0	0.0/1.0	0.698/1.0
<i>histogram</i>								
<i>density of bad triangles</i>								

Edge Groups Occurrence

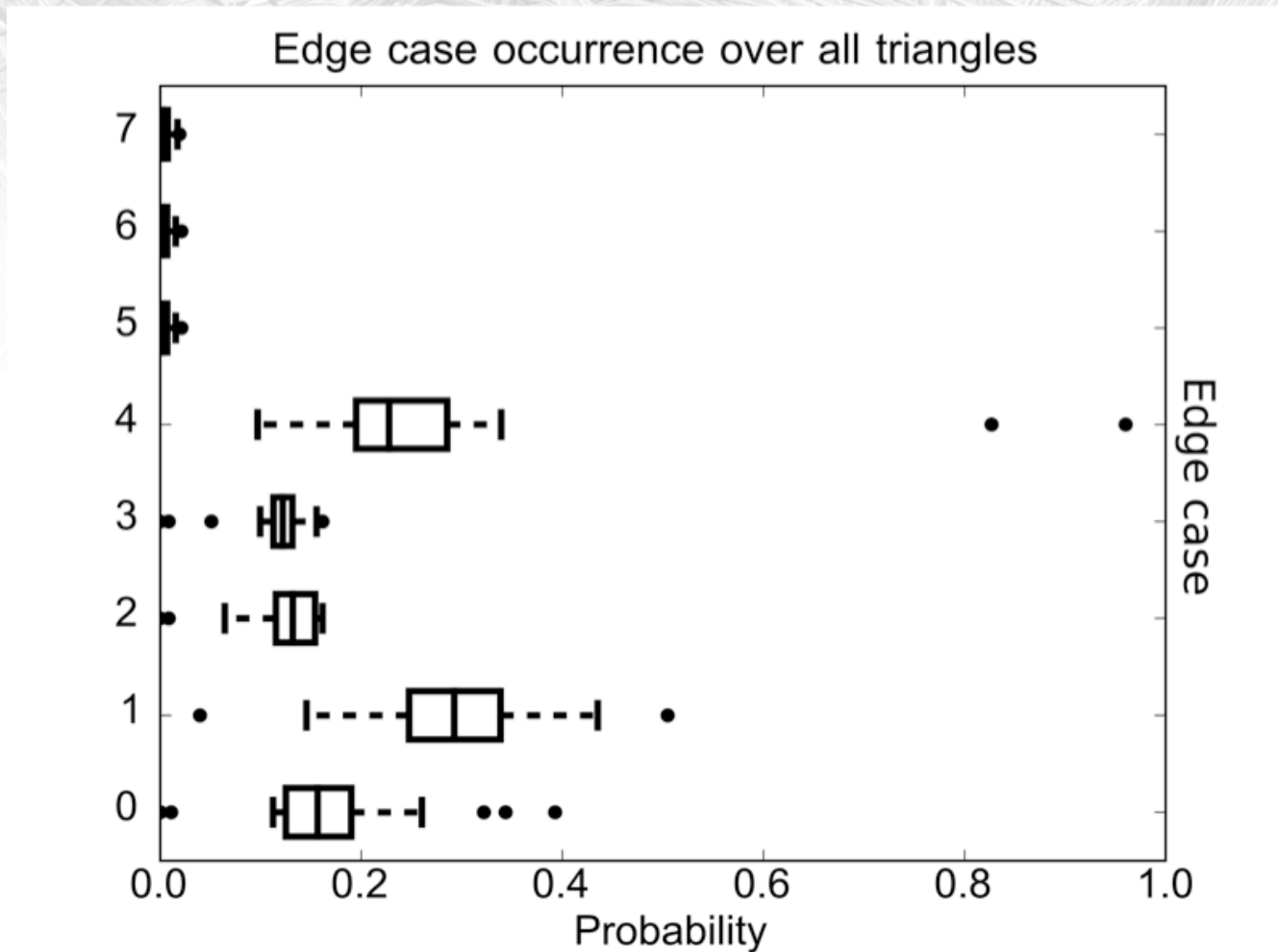

30 datasets

Interesting Observation: Edge Group 2 dominates

Edge case occurrence over worst 1000 triangles

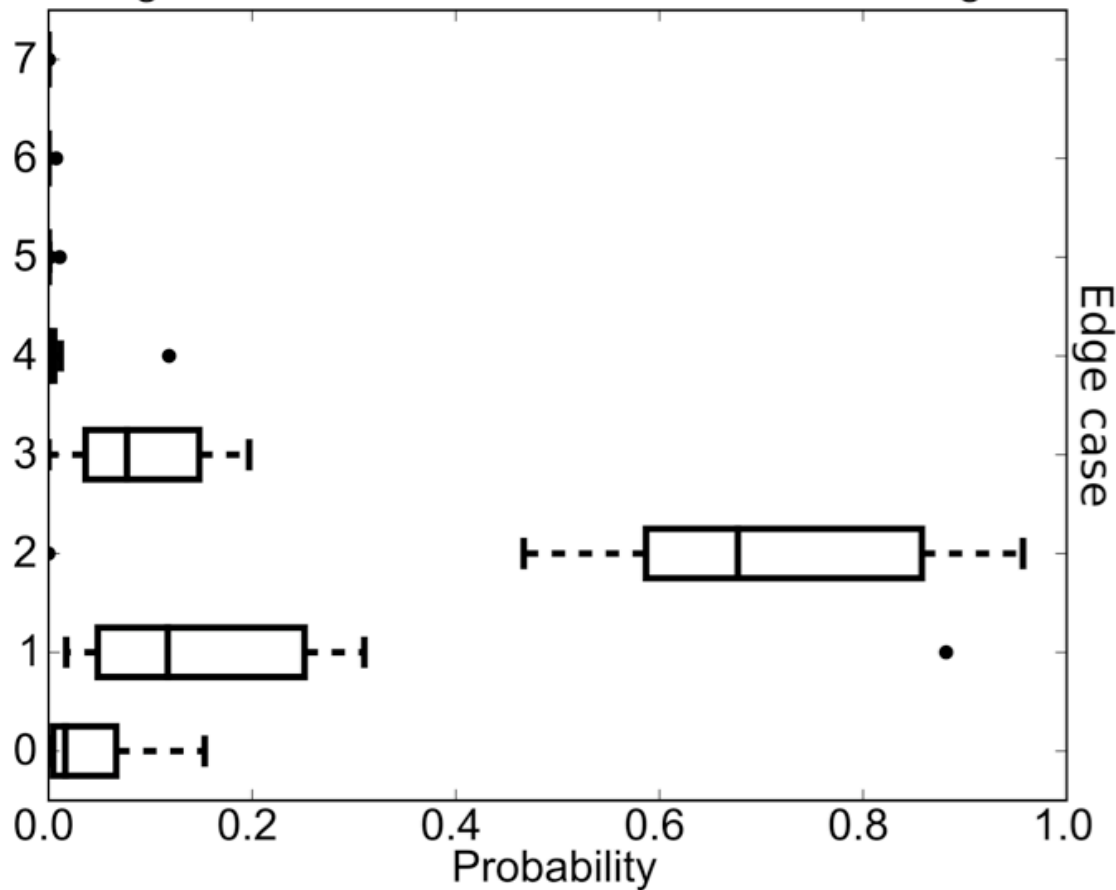

30 datasets

Outline



- Motivation
- Edge Groups in Cubic Cells
- **Improving Triangle Quality Based on Edge Groups**
- Results
- Conclusions

Improving Triangle Quality based on Edge Groups

- Observation 1 : **Edge Group 2** generates the worst triangles
 - Changing the MC table

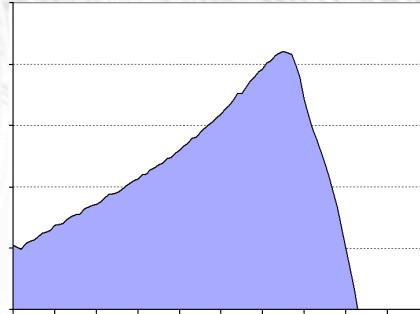

- Observation 2: **Bad triangles when isosurface is parallel to the edge**
 - Edge transformations using Macet [Dietrich et al 2009]

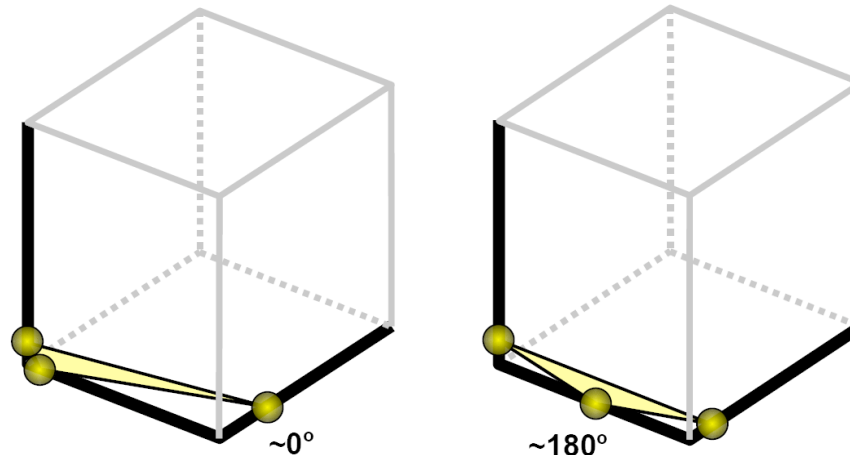

Improvement 1: Changing MC Table

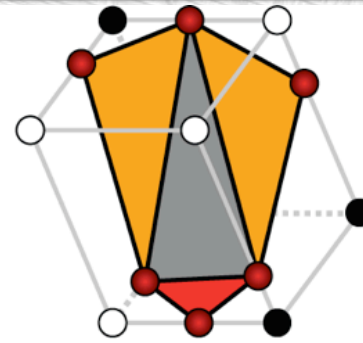
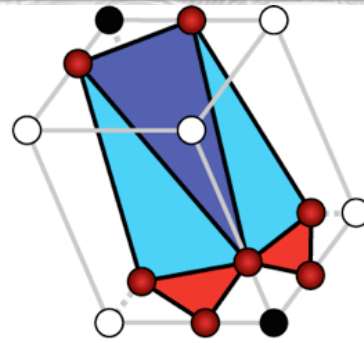
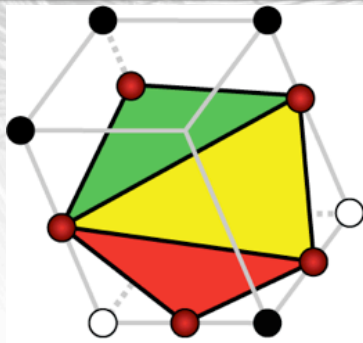

-  Group 1
-  Group 2
-  Group 3
-  Group 4
-  Group 5
-  Group 6
-  Group 7

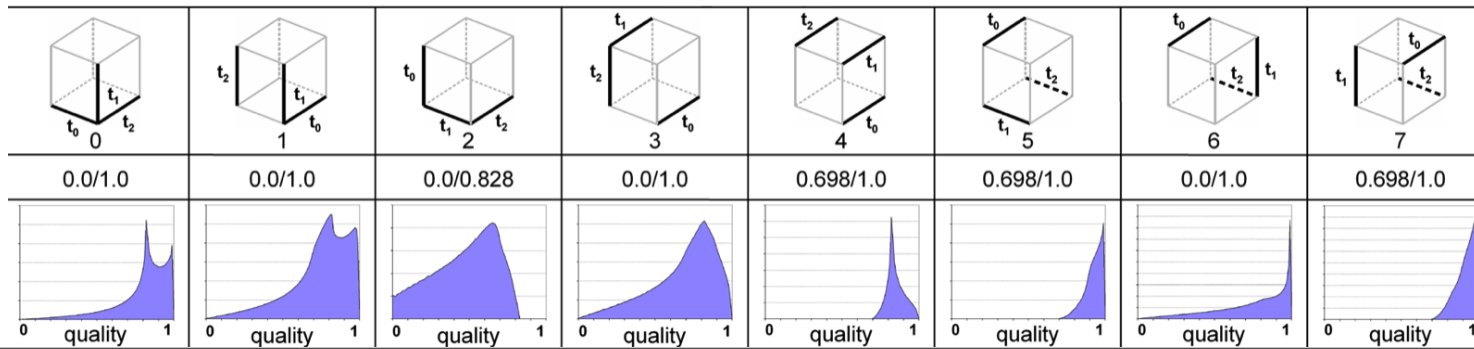

Improvement 2: Edge Transformations using Macet

- Macet [Dietrich et al 2009]
 - Edge transformations alter positions of grid points in MC

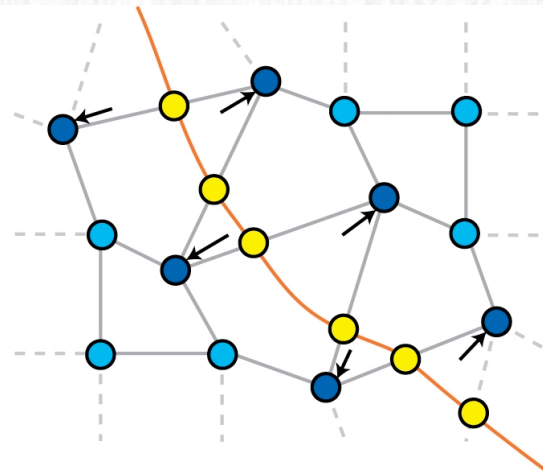
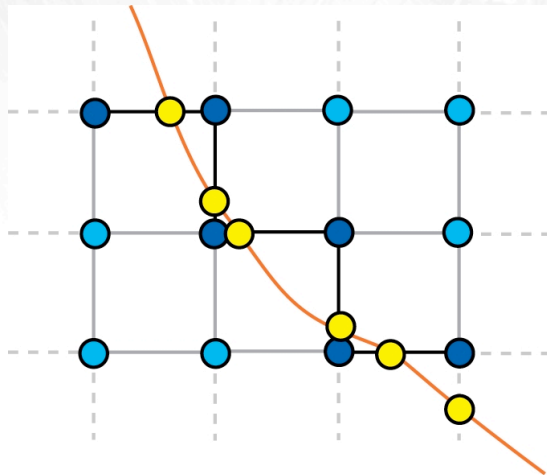

Gradient Transformation

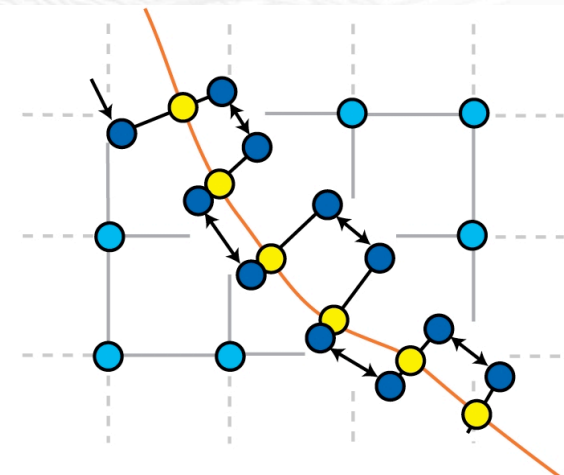

Tangent Transformation

Improvement 2: Edge Transformations using Macet

- Displacement of Intersection Vertices

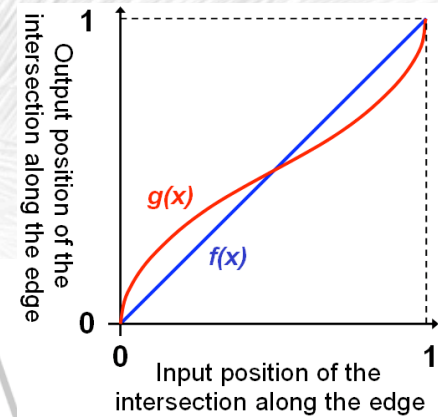
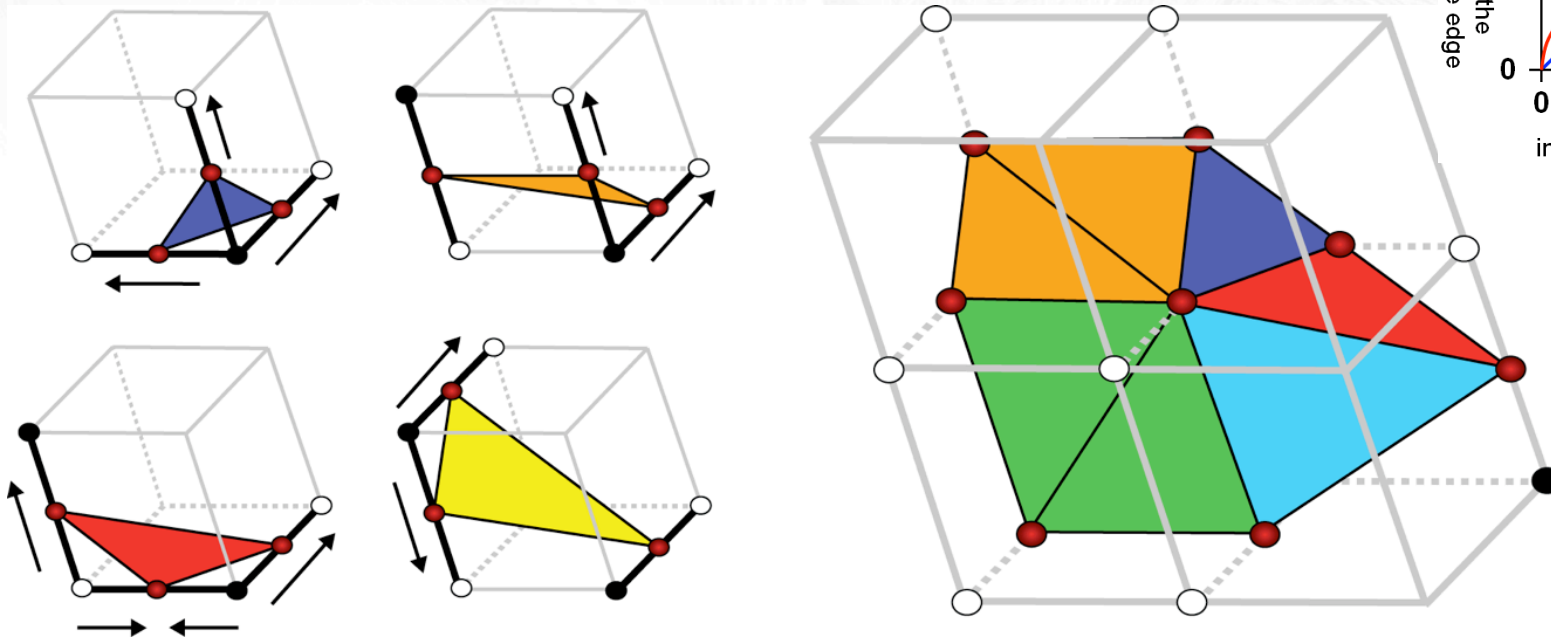

Improvement 2: Edge Transformations using Macet

	Edge Groups							
Quality								
<i>min/max</i>	0.0/1.0	0.0/1.0	0.0/0.828	0.0/1.0	0.698/1.0	0.698/1.0	0.0/1.0	0.698/1.0
<i>histogram</i>								
<i>density of bad triangles</i>								

Improvement 2: Edge Transformations using Macet

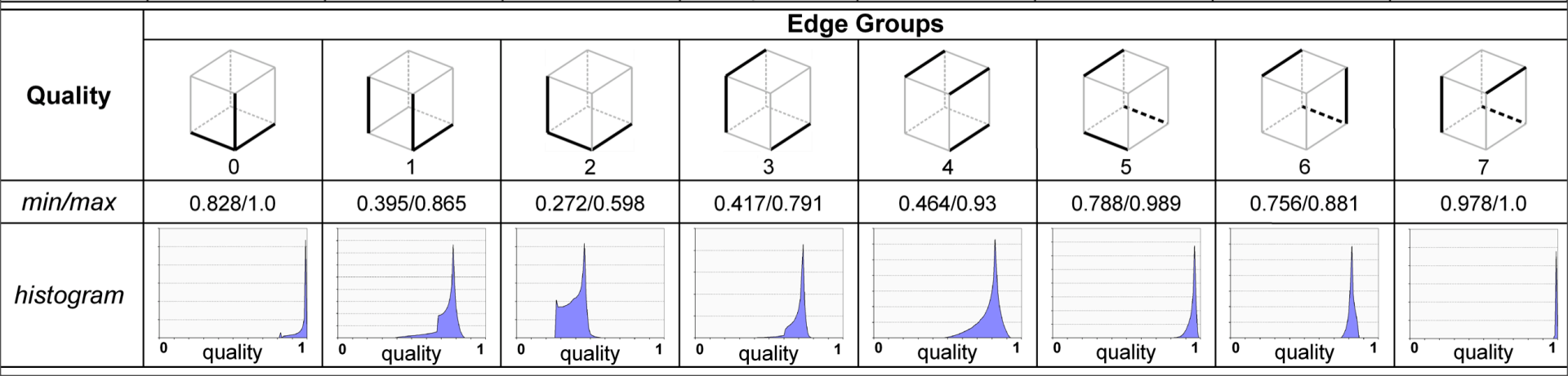
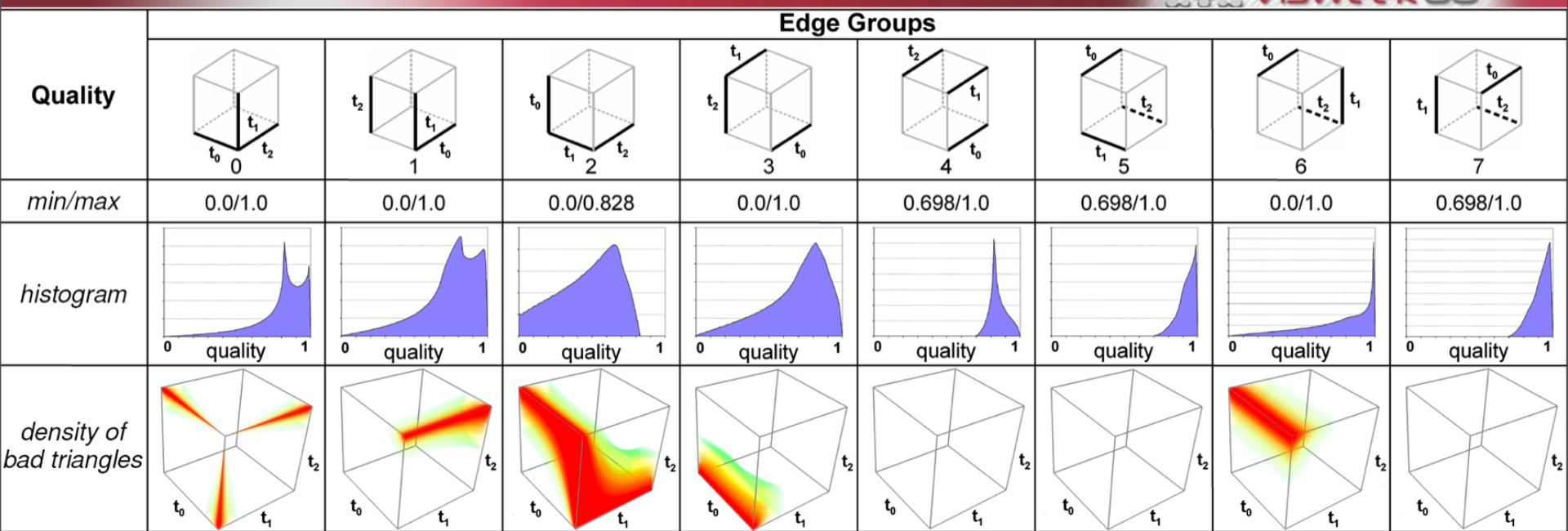

Summary of Changes to Marching Cubes Code

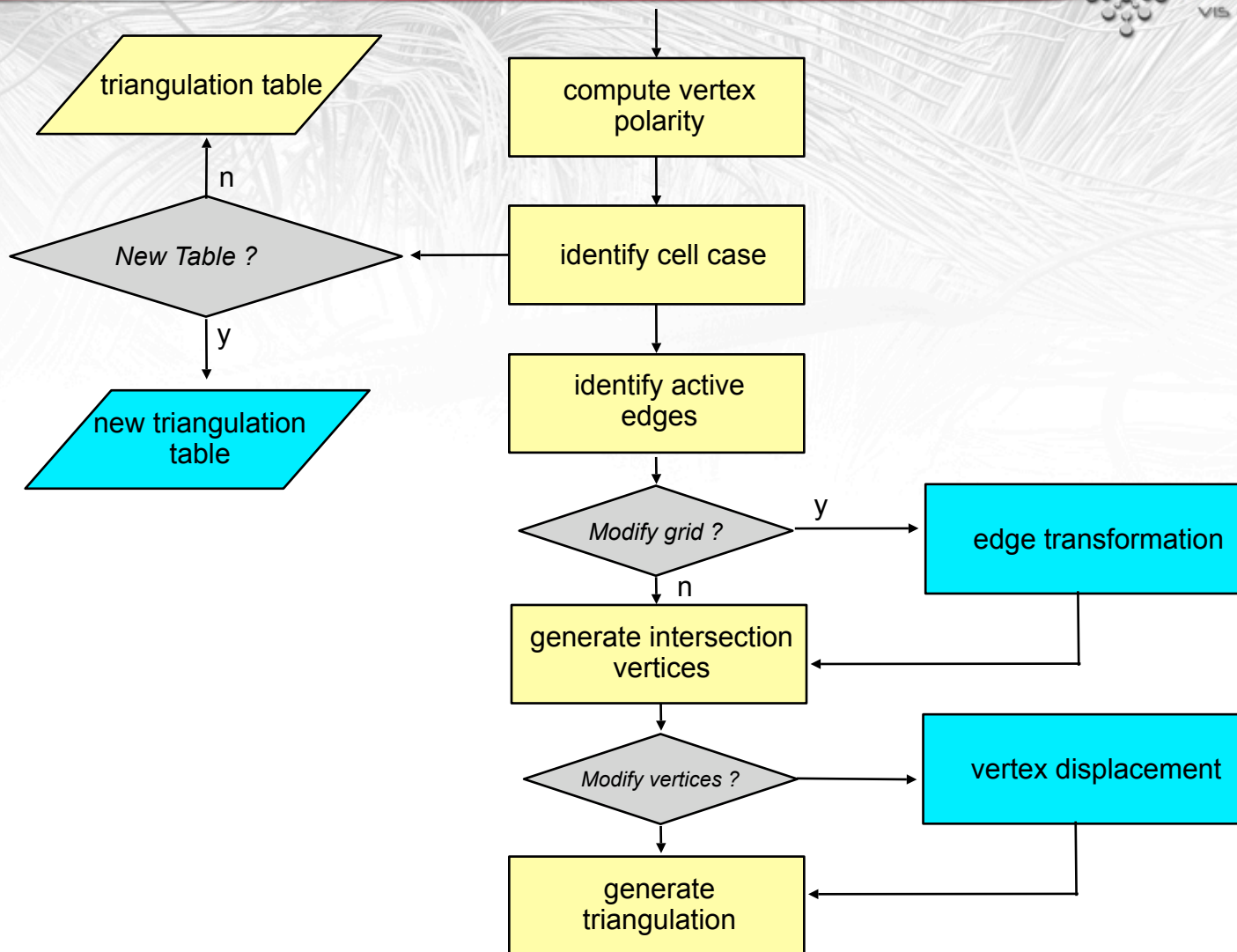

Outline



- Motivation
- Edge Groups in Cubic Cells
- Improving Triangle Quality Based on Edge Groups
- **Results**
- Conclusions

Results

	Original MC Old Table	Macet Old Table	Original MC New Table	Macet New Table Displacements
Silicium @ 140.5	0.00157			
Engine @ 49.5	0.00042			
Bonsai @ 49.5	0.00013			
Lobster @ 49.5	0.00088			

Results



	Original MC Old Table	Macet Old Table	Original MC New Table	Macet New Table Displacements
Silicium @ 140.5	0.00157		0.01792	
Engine @ 49.5	0.00042		0.00080	
Bonsai @ 49.5	0.00013		0.00152	
Lobster @ 49.5	0.00088		0.00153	

Results



	Original MC Old Table	Macet Old Table	Original MC New Table	Macet New Table Displacements
Silicium @ 140.5	0.00157	0.199	0.01792	
Engine @ 49.5	0.00042	0.235	0.00080	
Bonsai @ 49.5	0.00013	0.102	0.00152	
Lobster @ 49.5	0.00088	0.116	0.00153	

Results



	Original MC Old Table	Macet Old Table	Original MC New Table	Macet New Table Displacements
Silicium @ 140.5	0.00157	0.199	0.01792	0.344
Engine @ 49.5	0.00042	0.235	0.00080	0.293
Bonsai @ 49.5	0.00013	0.102	0.00152	0.195
Lobster @ 49.5	0.00088	0.116	0.00153	0.247

Edge Groups in Tetrahedra Cells

- Extensions to tetrahedra cells **BCC Tetrahedra (4 Edge Groups)**

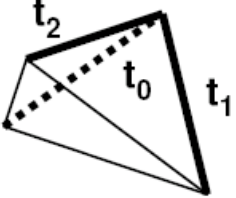
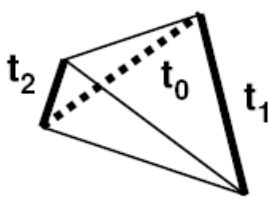
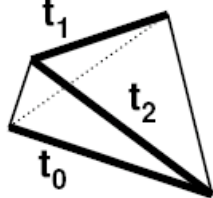
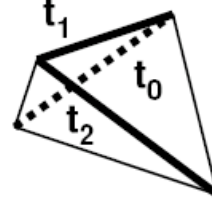
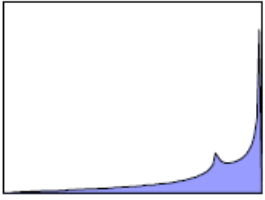
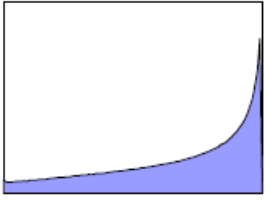
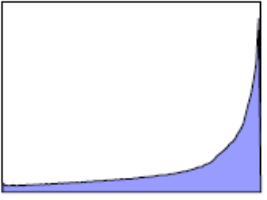
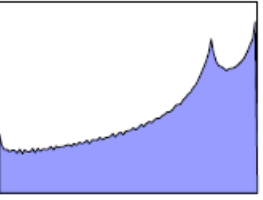
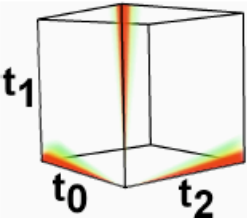
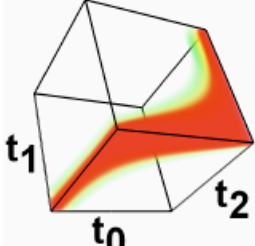
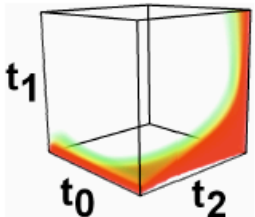
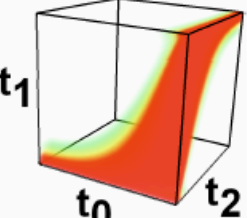
Quality	 0	 1	 2	 3
<i>min/max</i>	0.0/1.0	0.0/1.0	0.0/1.0	0.0/1.0
<i>histogram</i>	 0 quality 1	 0 quality 1	 0 quality 1	 0 quality 1
<i>density of bad triangles</i>	 t1 t0 t2	 t1 t0 t2	 t1 t0 t2	 t1 t0 t2

Edge Groups in Tetrahedra Cells

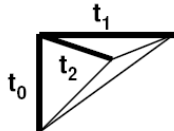
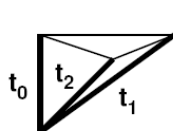
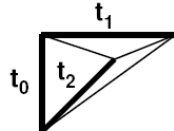
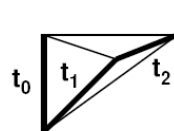
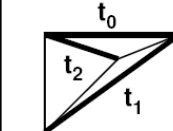
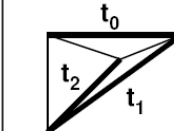
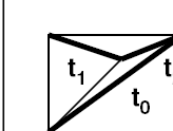
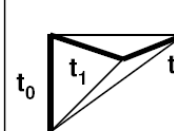
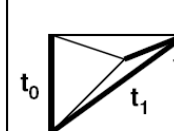
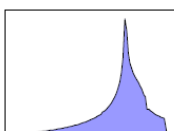
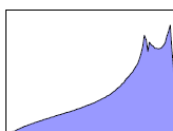
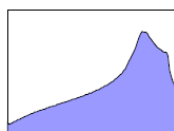
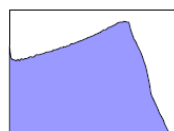
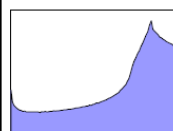
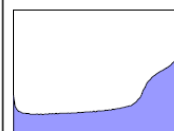
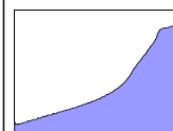
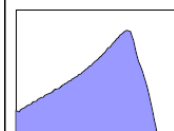
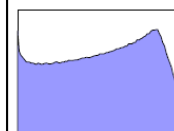
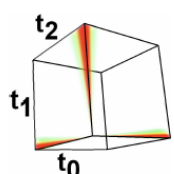
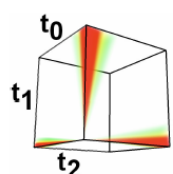
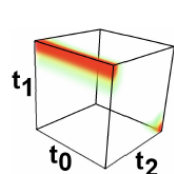
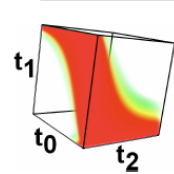
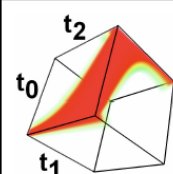
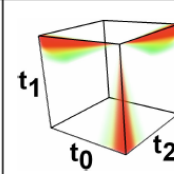
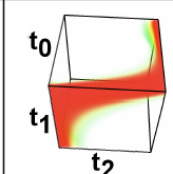
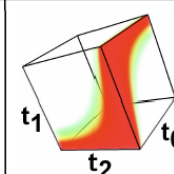
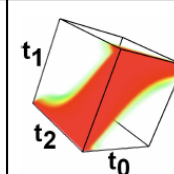
Quality									
	0	1	2	3	4	5	6	7	8
<i>min/max</i>	0/0.945	0.0/1.0	0.0/1.0	0/0.945	0.0/1.0	0.0/1.0	0.0/1.0	0/0.828	0/0.976
<i>histogram</i>									
	0 quality 1	0 quality 1	0 quality 1	0 quality 1	0 quality 1	0 quality 1	0 quality 1	0 quality 1	0 quality 1
<i>density of bad triangles</i>									
	t2 t1 t0	t0 t1 t2	t1 t0 t2	t0 t1 t2	t2 t0 t1	t1 t0 t2	t0 t1 t2	t1 t2 t0	t1 t2 t0

Kuhn Tetrahedra (9 Edge Groups)

Ongoing Work

- Unified Edge Transformations Macet (Technical Report coming soon)
 - Single Edge Transformation
 - Optional Vertex Displacement
 - More efficient, more quality

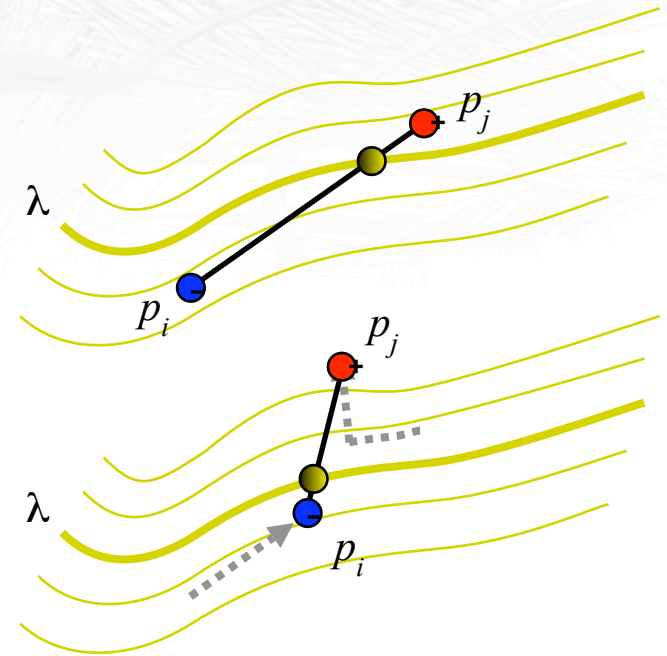
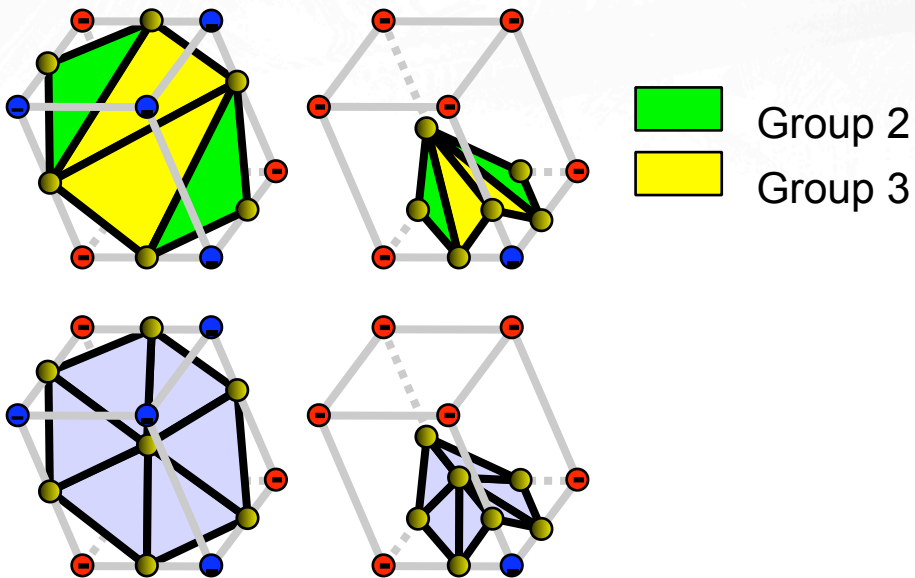

Latest Quality and Performance Results



- Unified Edge Transformations Macet

	MC		Unified Macet	
	<i>time</i>	<i>quality</i>	<i>time</i>	<i>quality</i>
<i>Bonsai</i>	1.4	0.0002	9.9	0.32
<i>Engine</i>	1.1	0.0002	8.6	0.35
<i>Hydrogen</i>	0.15	0.069	0.7	0.52
<i>Laçador</i>	0.7	4.8e-7	2	0.37
<i>Neghip</i>	0.07	0.0031	0.64	0.38
<i>Siliicum</i>	0.03	0.0009	0.38	0.41

Demo

- Side-by-side comparison: MC x Unified Macet

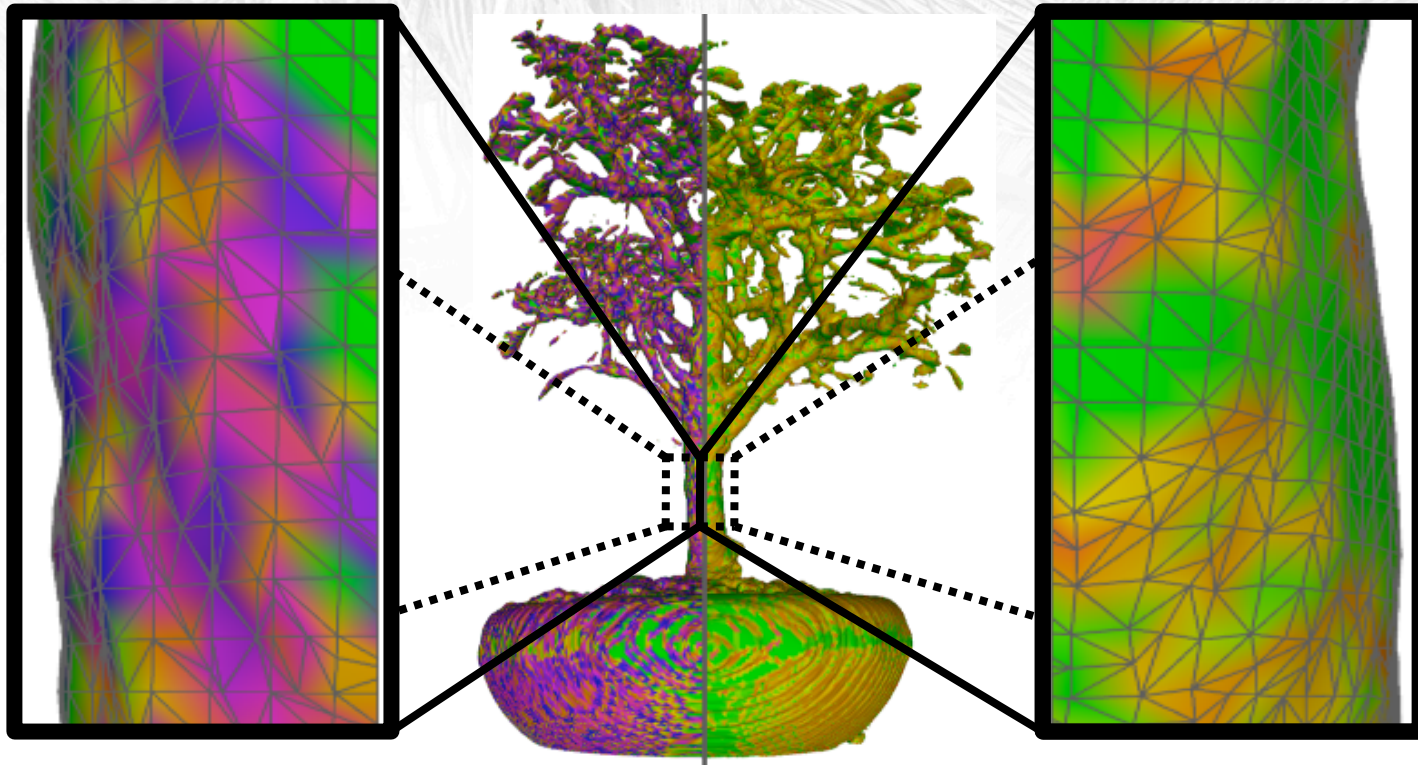

Marching Cubes

Macet

Conclusions



- Main contributions:
 - Edge groups proposal and analysis in MC:
 - Histogram analysis of each individual case
 - Case 2 generates the worst triangles
 - Modifications in MC
 - Change of MC table
 - Improvements and Validation of Macet
 - Reproducibility (open source):
 - <http://www.sci.utah.edu/~cscheid/vis2008/edge-groups> (Vistrails)

Acknowledgments



- CNPq (Brazil) scholarship and grants 485853/2007-0, 453538/2008-8
- IBM Ph.D. Student Fellowship.
- Department of Energy SciDAC (VACET and SDM centers)
- National Science Foundation (grants CNS-0751152, CCF-0528201, OCE-0424602, CNS-0514485, IIS-0513692, CCF-0401498, OISE-0405402, CNS-0551724)
- IBM Faculty Awards (2005, 2006, and 2007)
- Reviewers for feedback

Questions ?

